



NM20

MOTOR PROTECTION RELAY

MULTIFUNCTION PROTECTION FOR LARGE SIZE MOTORS

— Application

The relay type NM20 can be used for protection of large size motors in MV systems with any grounded systems (solidly grounded, ungrounded or Petersen coil and/or resistance grounded) on feeders of any length.

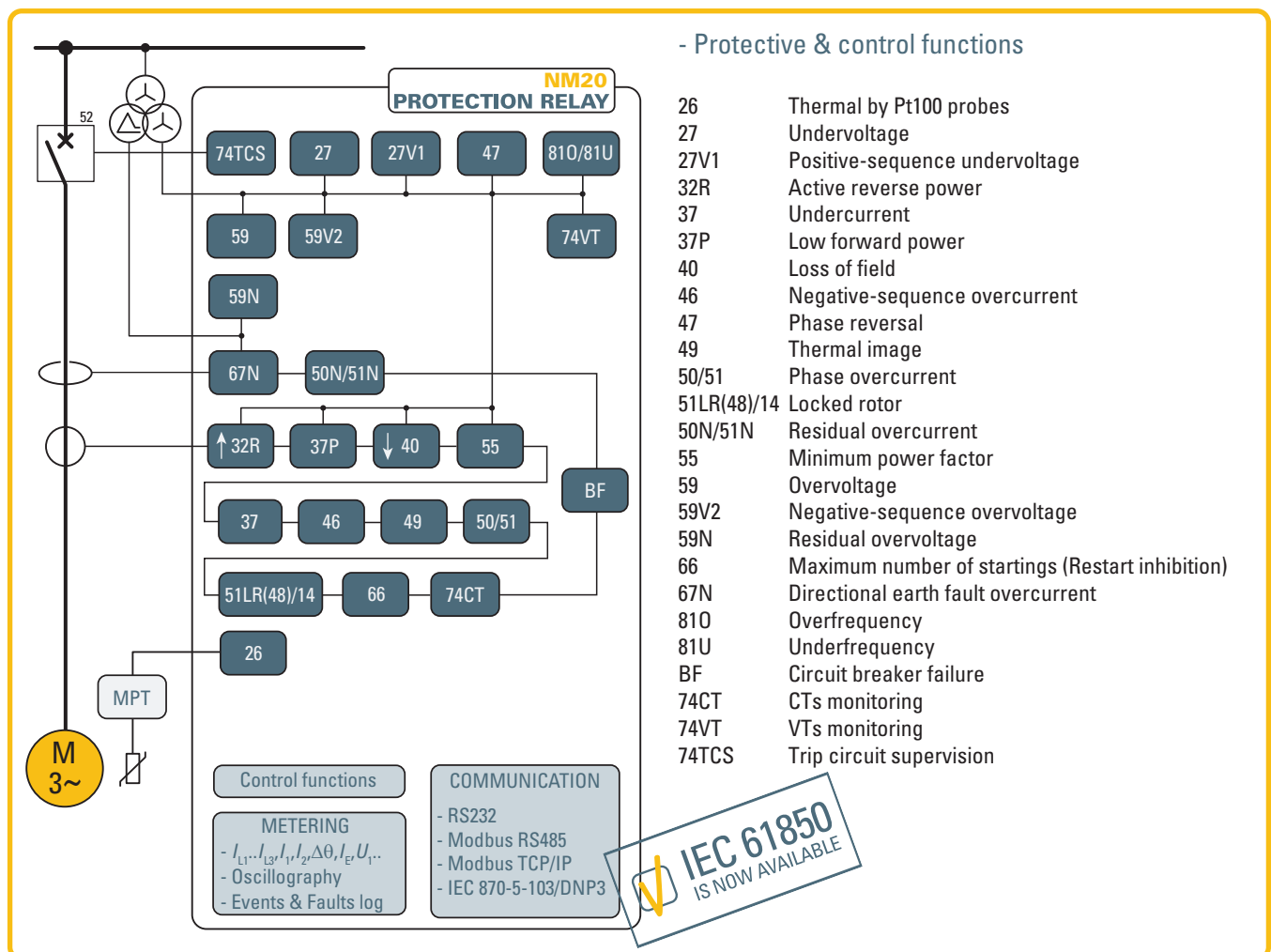

Measuring inputs

- Three phase current inputs and one residual current input, with nominal currents independently selectable at 1 A or 5 A through DIP-switches.
- Three phase voltage inputs with programmable nominal voltages within range 50...130 V ($U_R=100$ V) or 200...520 V ($U_R=400$ V) and one residual voltage input, with programmable nominal voltage within range 50...130 V ($U_{ER}=100$ V).

Note - Polarity and phase sequence of currents and voltages inputs may be set by the user.

Firmware updating

The use of flash memory units allows on-site firmware updating.

Two set point profiles (A,B)

Two independent groups of settings are provided. Switching from profiles may be operated by means of MMI, binary input and communication.

Construction

According to the hardware configurations, the NM20 protection relay can be shipped in various case styles depending on the required mounting options (flush, projecting mounting, rack or with separate operator panel).

Binary inputs

Two binary inputs are available with programmable active state (active-ON/active-OFF) and programmable timer (active to OFF/ON or ON/OFF transitions). Several presettable functions can be associated to each input.

Modular design

In order to extend I/O capability, the NM20 hardware can be customized through external auxiliary modules:

- MRI - Output relays and LEDs
- MID16 - Binary inputs
- MCI - 4...20 mA converter
- MPT - Pt100 probe inputs.



Blocking output

One output blocking circuit is provided. The output blocking circuits of one or several Pro_N relays, shunted together, must be connected to the input blocking circuit of the protection relay, which is installed upstream in the electric plant. The output circuit works as a simple contact, whose condition is detected by the input circuit of the upstream protection relay. For long distances, when high insulation and high EMC immunity is essential, a suitable pilot wire to fiber optic converter (BFO) is available.

Output relays

Six output relays are available (two changeover, three make and one break contacts); each relay may be individually programmed as normal state (normally energized, de-energized or pulse) and reset mode (manual or automatic). A programmable timer is provided for each relay (minimum pulse width). The user may program the function of each relay according to a matrix (tripping matrix) structure.

Programming and settings

All relay programming and adjustment operations may be performed through MMI (Keyboard and display) or using a Personal Computer with the aid of the ThySetter software. The same PC setup software is required to set, monitor and configure all Pro_N devices.

Full access to the available data is provided:

- Read status and measures.
 - Read/edit settings (on-line or off-line edit).
- Two session level (User or Administrator) with password for sensible data access are provided.

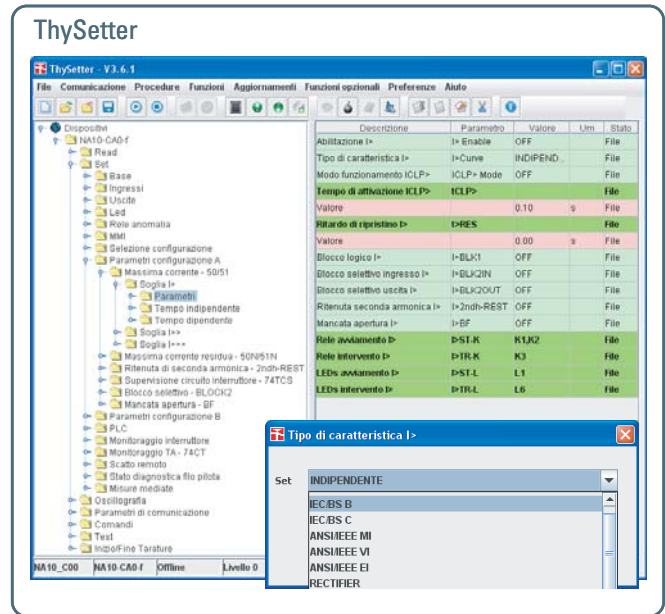

Communication

Multiple communication interfaces are implemented:

- One RS232 local communication front-end interface for communication with ThySetter setup software
- Two back-end interfaces for communication with remote monitoring and control systems by:
 - RS485 port using ModBus® RTU, IEC 60870-5-103 or DNP3 protocol.
 - Ethernet port (RJ45 or optical fiber) using ModBus/TCP or IEC61850 protocol.

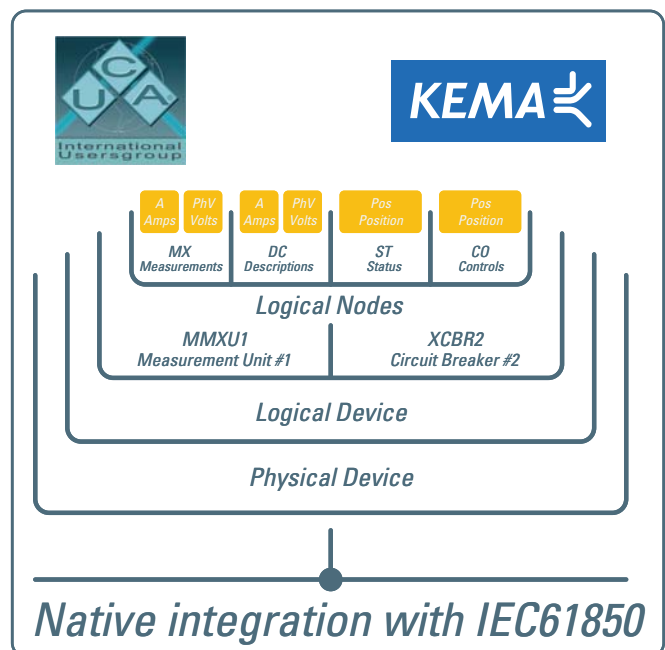

Native integration with IEC61850

— MMI (Man Machine Interface)

The user interface comprises a membrane keyboard, a backlight LCD alphanumeric display and eight LEDs.

The green ON LED indicates auxiliary power supply and self diagnostics, two LEDs are dedicated to the Start and Trip (yellow for Start, red for Trip) and five red LEDs are user assignable.



— Control and monitoring

Several predefined functions are implemented:

- Activation of two set point profiles
- Phase CTs monitoring (74CT)
- Phase VTs monitoring (74VT)
- Logic selectivity
- Cold load pickup (CLP) with block or setting change
- Trip circuit supervision (74TCS)
- Remote tripping
- Synchronization
- Circuit Breaker commands and diagnostic

Moreover user defined logic must be customized in accordance with IEC 61131-3 protocol by means programmable logic controller (PLC).

Circuit Breaker

Several diagnostic, monitoring and control functions are provided:

- Health thresholds can be set; when the accumulated duty (ΣI or ΣI^2t), the number of operations or the opening time exceeds the threshold an alarm is activated.
- Breaker failure (BF); breaker status is monitored by means 52a-52b and/or through line current measurements.
- Trip circuit supervision (74TCS).
- Breaker control; opening and closing commands can be carried out locally or remotely.

Virtual I/O

Through ThySetter and ThyVisor tools the type of operation and links between eight outputs (Virtual Output - VOUT1 ... 8) and ten virtual inputs (Virtual Inputs - VIN1 ... VIN10) may be defined using RPC or IEC 61850 communication protocols over Ethernet network.

The system allows:

- Availability of eight inputs and ten outputs independently programmable by the user
- Simplify wiring using one channel as the Ethernet
- Eliminate the need to install communication devices and / or external conversion
- Significantly reduce costs
- Dynamically change from sw connections and associated functions.

The virtual I / O can be usefully employed for:

- Transmit information between protections installed in distance
- Achieve accelerated logic discrimination in which some protection elements can be blocked by the activation of the downstream protection start
- Circuit Breaker commands, Selection of setting profiles, Remote trip, etc...

Logic selectivity

With the aim of providing a fast selective protection system some protective functions may be blocked.

The selectivity logic may be accomplished by:

- input and output block circuits,
- output relays and logic inputs,
- virtual input and output with messages on Ethernet network.

To guarantee maximum fail-safety, the relay performs a run time monitoring for pilot wire continuity and pilot wire shorting. Exactly the output blocking circuit periodically produces a pulse, with small width in order to be ignored as an effective blocking signal by the input blocking circuit of the upstream protection, but suitable to prove continuity of the pilot wire.

Furthermore a permanent activation (or better, with a duration longer than a preset time) of the blocking signal is identified, as a warning for a possible short circuit in the pilot wire or in the output circuit of the downstream protection.

Cold Load Pickup (CLP)

Cold load pickup element prevents unwanted tripping in case of temporary overcurrents produced when a feeder is being connected after an extended outage (e.g. motor starting).

Two different operating modes are provided:

- Each protective element can be blocked for a setting time.
- Each threshold can be increased for a setting time.

— Self diagnostics

All hardware and software functions are repeatedly checked and any anomalies reported via display messages, communication interfaces, LEDs and output relays.

Anomalies may refer to:

- Hw faults (auxiliary power supply, output relay coil interruptions, MMI board...)
- Sw faults (boot and run time tests for data base, EEPROM memory checksum failure, data BUS,...)
- Circuit breaker faults.

— Metering

NM20 provides metering values for phase and residual currents and voltages, making them available for reading on a display or to communication interfaces. Input signals are sampled 24 times per period and the RMS value of the fundamental component is measured using the DFT (Discrete Fourier Transform) algorithm and digital filtering. With DFT the RMS value of 2nd, some harmonic of phase current are also measured.

On the base of the direct measurements, the minimum-peak-fixed-rolling demand, mean-minimum-maximum absolute phase currents, active and reactive power/energy, power factor are processed. The measured signals can be displayed with reference to nominal values or directly expressed in amperes, volts, watt, var, wh and varh.

— Event storage

Several useful data are stored for diagnostic purpose; the events are stored into a non volatile memory.

They are graded from the newest to the older after the "Events reading" command (ThySetter) is issued:

- Sequence of Event Recorder (SER)
The event recorder runs continuously capturing in circular mode the last three hundred events upon trigger of binary input/output.
- Sequence of Fault Recorder (SFR)
The event recorder runs continuously capturing in circular mode the last twenty events upon trigger of binary input/output and/or element pickup (start-trip).
- Trip counters

— Digital Fault Recorder (DFR)

Upon trigger of tripping/starting of each function or external signals, the relay records in COMTRADE format:

- Oscillography with instantaneous values for transient analysis
- RMS values of the measured signals for long time periods analysis
- Logic states (binary inputs and output relays).

Note - A license for Digital Fault Recorder function is required, for purchase procedure please contact Thytronic.

The records are stored in nonvolatile memory

SPECIFICATIONS

GENERAL

| | |
|--|---|
| — Mechanical data | |
| Mounting: | flush, projecting, rack or separated operator panel |
| Mass (flush mounting case) | 2.0 kg |
| — Insulation tests | |
| Reference standards | EN 60255-5 |
| High voltage test 50Hz | 2 kV 60 s |
| Impulse voltage withstand (1.2/50 μ s) | 5 kV |
| Insulation resistance | >100 M Ω |
| — Voltage dip and interruption | |
| Reference standards | EN 61000-4-29 |
| — EMC tests for interference immunity | |
| 1 MHz damped oscillatory wave | EN 60255-22-1 1 kV-2.5 kV |
| Electrostatic discharge | EN 60255-22-2 8 kV |
| Fast transient burst (5/50 ns) | EN 60255-22-4 4 kV |
| Conducted radio-frequency fields | EN 60255-22-6 10 V |
| Radiated radio-frequency fields | EN 60255-4-3 10 V/m |
| High energy pulse | EN 61000-4-5 2 kV |
| Magnetic field 50 Hz | EN 61000-4-8 1 kA/m |
| Damped oscillatory wave | EN 61000-4-12 2.5 kV |
| Ring wave | EN 61000-4-12 2 kV |
| Conducted common mode (0...150 kHz) | EN 61000-4-16 10 V |
| — Emission | |
| Reference standards | EN 61000-6-4 (ex EN 50081-2) |
| Conducted emission 0.15...30 MHz | Class A |
| Radiated emission 30...1000 MHz | Class A |
| — Climatic tests | |
| Reference standards | IEC 60068-x, ENEL R CLI 01, CEI 50 |
| — Mechanical tests | |
| Reference standards | EN 60255-21-1, 21-2, 21-3 |
| — Safety requirements | |
| Reference standards | EN 61010-1 |
| Pollution degree | 3 |
| Reference voltage | 250 V |
| Overvoltage | III |
| Pulse voltage | 5 kV |
| Reference standards | EN 60529 |
| <i>Protection degree:</i> | |
| • Front side | IP52 |
| • Rear side, connection terminals | IP20 |
| — Environmental conditions | |
| Ambient temperature | -25...+70 °C |
| Storage temperature | -40...+85 °C |
| Relative humidity | 10...95 % |
| Atmospheric pressure | 70...110 kPa |
| — Certifications | |
| Product standard for measuring relays | EN 50263 |
| <i>CE conformity</i> | |
| • EMC Directive | 89/336/EEC |
| • Low Voltage Directive | 73/23/EEC |
| Type tests | IEC 60255-6 |

COMMUNICATION INTERFACES

| | |
|---------------------|--|
| Local PC RS232 | 19200 bps |
| <i>Network:</i> | |
| • RS485 | 1200...57600 bps |
| • Ethernet 100BaseT | 100 Mbps |
| Protocol | ModBus® RTU/IEC 60870-5-103/DNP3, TCP/IP, IEC61850 |

INPUT CIRCUITS

| | |
|--|--|
| — Auxiliary power supply Uaux | |
| Nominal value (range) | 24...48 Vac/dc, 115...230 Vac/110...220 Vdc |
| Operative range (each one of the above nominal values) | 19...60 Vac/dc 85...265 Vac/75...300 Vdc |
| <i>Power consumption:</i> | |
| • Maximum (energized relays, Ethernet TX) | 10 W (20 VA) |
| • Maximum (energized relays, Ethernet FX) | 15 W (25 VA) |
| — Phase current inputs | |
| Nominal current I_n | 1 A or 5 A selectable by DIP Switches |
| Permanent overload | 25 A |
| Thermal overload (1s) | 500 A |
| Rated consumption (for any phase) | ≤ 0.002 VA ($I_n = 1$ A) ≤ 0.04 VA ($I_n = 5$ A) |
| — Residual current input | |
| Nominal current I_{En} | 1 A or 5 A selectable by DIP Switch |
| Permanent overload | 25 A |
| Thermal overload (1s) | 500 A |
| Rated consumption | ≤ 0.006 VA ($I_{En} = 1$ A), ≤ 0.012 VA ($I_{En} = 5$ A) |
| — Voltage inputs | |
| Reference voltage U_R | 100 V or 400 V selectable on order |
| Nominal voltage U_n | 50...130 V or 200...520 V selectable by sw |
| Permanent overload | 1.3 U_R |
| 1s overload | 2 U_R |
| Rated consumption (for any phase) | ≤ 0.5 VA |
| — Residual voltage input | |
| Reference voltage U_{ER} | 100 V |
| Nominal voltage U_{En} | 50...130 V adjustable via sw |
| Permanent overload | 1.3 U_{ER} |
| 1 s overload | 2 U_{ER} |
| Rated consumption | ≤ 0.5 VA |
| — Binary inputs | |
| Quantity | 2 |
| Type | dry inputs |
| Max permissible voltage | 19...265 Vac/19...300 Vdc |
| Max consumption, energized | 3 mA |
| — Pt100 inputs (MPT module) | |
| Quantity | 8 |
| Range | 0...200 °C |

OUTPUT CIRCUITS

| | |
|---|---------------------------|
| — Output relays K1...K6 | |
| Quantity | 6 |
| • Type of contacts K1, K2 | changeover (SPDT, type C) |
| • Type of contacts K3, K4, K5 | make (SPST-NO, type A) |
| • Type of contacts K6 | break (SPST-NC, type B) |
| Nominal current | 8 A |
| Nominal voltage/max switching voltage | 250 Vac/400 Vac |
| <i>Breaking capacity:</i> | |
| • Direct current (L/R = 40 ms) | 50 W |
| • Alternating current ($\lambda = 0,4$) | 1250 VA |
| Make | 1000 W/VA |
| Short duration current (0,5 s) | 30 A |
| — Block output (Logic selectivity) | |
| Quantity | 1 |
| Type | optocoupler |
| — LEDs | |
| Quantity | 8 |
| • ON/fail (green) | 1 |
| • Start (yellow) | 1 |
| • Trip (red) | 1 |
| • Allocatable (red) | 5 |

GENERAL SETTINGS

Rated values

| | |
|--|---------------------------|
| Relay nominal frequency (f_n) | 50, 60 Hz |
| Relay phase nominal current I_n | 1 A, 5 A |
| Phase CTs nominal primary current I_{np} | 1 A...10 kA |
| Relay residual nominal current I_{En} | 1 A, 5 A |
| Residual CT nominal primary current I_{Enp} | 1 A...10 kA |
| Relay nominal voltage (phase-to-phase) (U_n) | 50...130 V or 200...520 V |
| Relay nominal voltage (phase-to-ground) $E_n = U_n/\sqrt{3}$ | - |
| Line VT primary nominal voltage (phase-to-phase) (U_{np}) | 50 V...500 kV |
| Relay residual nominal voltage (direct measure) (U_{En}) | 50...130 V |
| Residual primary nominal voltage (phase-to-phase) $\sqrt{3} (U_{Enp})$ | 50 V...500 kV |

Binary input timers

| | |
|---|----------------|
| ON delay time (IN1 t_{ON} , INx t_{ON}) | 0.00...100.0 s |
| OFF delay time (IN1 t_{OFF} , INx t_{OFF}) | 0.00...100.0 s |

Relay output timers

| | |
|------------------------------|-----------------|
| Minimum pulse width t_{TR} | 0.000...0.500 s |
|------------------------------|-----------------|

Starting control

| | |
|-------------|------------|
| CLP control | IRUN or CB |
|-------------|------------|

PROTECTIVE FUNCTIONS

Base current - IB

| | |
|------------------------|-------------------|
| Base current (I_B) | 0.20...1.50 I_n |
|------------------------|-------------------|

Note - Assuming that the secondary rated current of the line CT's equals the rated current of the relay, as usually happens, the I_B value is the ratio between the rated current of the protected motor and the primary rated current of the CT's.

Thermal with PT100 thermometric probes - 26

PTx probe (x = 1...8):

ThALx Alarm

| | |
|--|------------|
| • PTx Alarm threshold ($ThALx$) | 0...200 °C |
| • ThALx Operating time (t_{ThALx}) | 0...100 s |

Th>x Trip

| | |
|--------------------------------------|------------|
| • PTx Trip threshold ($Th>x$) | 0...200 °C |
| • Th>1 Operating time ($t_{Th>x}$) | 0...100 s |

Note - The element is available when the MPT module, connected to the Thybus, is enabled

Undervoltage - 27

Common configuration:

| | |
|---|----------------------|
| • Voltage measurement type for 27 (U_{type27}) ^[1] | U_{ph-ph}/U_{ph-n} |
| • 27 Operating logic ($Logic27$) | AND/OR |

U< Element

| | |
|---------------------------|----------------------------------|
| • U< Curve type (U<Curve) | DEFINITE, INVERSE ^[2] |
|---------------------------|----------------------------------|

Definite time

| | |
|---|-----------------------|
| • 27 First threshold definite time ($U_{<def}$) | 0.05...1.10 U_n/E_n |
| • U<def Operating time ($t_{U<def}$) | 0.03...100.0 s |

Inverse time

| | |
|--|-----------------------|
| • 27 First threshold inverse time ($U_{<inv}$) | 0.05...1.10 U_n/E_n |
| • U<inv Operating time ($t_{U<inv}$) | 0.10...100.0 s |

U<< Element

Definite time

| | |
|---|-----------------------|
| • 27 Second threshold definite time ($U_{<<def}$) | 0.05...1.10 U_n/E_n |
| • U<<def Operating time ($t_{U<<def}$) | 0.03...100.0 s |

Note [1] - With U_{ph-ph} setting all threshold are in p.u. U_n

With U_{ph-n} setting all threshold are in p.u. E_n

Note [2] - The mathematical formula for INVERSE curves is:

$$t = 0.75 \cdot t_{U<inv} / [1 - (U/U_{<inv})] \text{ where:}$$

t = trip time (in seconds)

$t_{U<inv}$ = operating time setting (in seconds)

U = input voltage

$U_{<inv}$ = threshold setting

Positive sequence undervoltage - 27V1

U1< Element

| | |
|--|-------------------|
| • 27V1 First threshold definite time ($U_{1<def}$) | 0.05...1.10 U_n |
| • U1<def Operating time ($t_{U1<def}$) | 0.03...100.0 s |

Active reverse power - 32R

P-> Element

| | |
|--|---------------------|
| • P-> Reset time delay ($t_{P->RES}$) | 0.00...100.0 s |
| • 32R First threshold definite time ($P->def$) | -1.00...-0.01 P_n |
| • P-> Operating time ($t_{P->def}$) | 0.07...100.0 s |

Undercurrent - 37

I< Element

| | |
|-----------------------------------|--------------|
| I< Inhibition time ($t_{inh<}$) | 0.00...200 s |
|-----------------------------------|--------------|

Definite time

| | |
|--|-------------------|
| • 37 First threshold definite time (I<def) | 0.30...1.00 I_B |
| • I<def Operating time ($t_{<def}$) | 0.10...600 s |

Underpower - 37P

P+< Element

| | |
|--|-------------------|
| • CB-37P delay ($t_{ARM-P+<}$) | 0.07...300 s |
| • 37P First threshold definite time ($P+<def$) | 0.01...1.20 P_n |
| • P+<def Operating time ($t_{P+<def}$) | 0.07...100.0 s |

Loss of field - 40

• Common configuration:

| | |
|---|-------------------|
| • Operating mode | Motor/Generator |
| • Undervoltage threshold ($U_{SUP<}$) | 0.50...1.00 U_n |

Alarm Element

| | |
|--------------------------------------|----------------|
| • 40AL Alpha angle α | 10...75° |
| • 40AL Operating time (t_{40AL}) | 0.07...100.0 s |

XC1-XD1 Element

| | |
|---|-----------------------|
| • XC1 Absolute center coordinate (X_{C1}) | 0.00...+4.50 Z_{nf} |
| • XD1 Diameter (X_{D1}) | 0.20...+5.00 Z_{nf} |
| • XC1-XD1 Operating time ($t_{XC1-XD1}$) | 0.07...100.0 s |
| • XC1-XD1 Reset time delay ($t_{XC1XD1-RES}$) | 0.0...10.0 s |

XC2-XD2 Element

| | |
|---|-----------------------|
| • XC2 Absolute center coordinate (X_{C2}) | 0.00...+4.50 Z_{nf} |
| • XD2 Diameter (X_{D2}) | 0.20...+5.00 Z_{nf} |
| • XC2-XD2 Operating time ($t_{XC2-XD2}$) | 0.07...100.0 s |
| • XC2-XD2 Reset time delay ($t_{XC2XD2-RES}$) | 0.0...10.0 s |

Negative sequence overcurrent - 46

I2> Element

| | |
|------------------------------------|--|
| • I2> Curve type ($I_{2>}Curve$) | DEFINITE IEC/BS A, B, C, ANSI/IEEE MI, VI, EI, EM, I ² t |
|------------------------------------|--|

| | |
|--|----------------|
| • I2CLP> Activation time ($t_{2CLP>}$) | 0.00...200 s |
| • I2> Reset time delay ($t_{2>RES}$) | 0.00...100.0 s |

Definite time

| | |
|--|-------------------|
| • 46 First threshold definite time ($I_{2>def}$) | 0.03...1.00 I_B |
| • I2>def within CLP ($I_{2CLP>def}$) | 0.03...5.00 I_B |
| • I2>def Operating time ($t_{2>def}$) | 0.03...200 s |

Inverse time

| | |
|---|-------------------|
| • 46 First threshold inverse time ($I_{2>inv}$) | 0.03...1.00 I_B |
| • I2>inv within CLP ($I_{2CLP>inv}$) | 0.03...5.00 I_B |
| • I2>inv Operating time ($t_{2>inv}$) | 0.10...60.0 s |

I2>> Element

| | |
|--|----------------|
| • I2CLP>> Activation time ($t_{2CLP>>}$) | 0.00...200 s |
| • I2>> Reset time delay ($t_{2>>RES}$) | 0.00...100.0 s |

Definite time

| | |
|--|-------------------|
| • 46 Second threshold definite time ($I_{2>>def}$) | 0.03...1.00 I_B |
| • I2>>def within CLP ($I_{2CLP>>def}$) | 0.03...5.00 I_B |
| • I2>>def Operating time ($t_{2>>def}$) | 0.03...200 s |

Phase reversal - 47

Definite time

| | |
|--------------------------------|-------------------|
| • Us1< threshold ($U_{s1<}$) | 0.05...0.30 E_n |
| • Us1> threshold ($U_{s1>}$) | 0.70...1.00 U_n |

Thermal image - 49

Common configuration:

| | |
|---|----------------------------|
| • Initial thermal image $\Delta\theta_{IN}$ (Dth_{IN}) | 0.0...1.0 $\Delta\theta_B$ |
| • Starting overload coefficient (K_{ST}) | 1.0...3.0 |
| • Negative sequence coefficient (K_2) | 0...10 |
| • Heating time constant τ_+ (T_+) | 1...200 min |
| • Cooling time constant τ_- (T_-) | 1...6 τ_+ |
| • DthCLP Operating mode (Dth_{CLP} ($Dth_{CLP Mode}$)) | Blocking/Change |
| • DthCLP Activation time (t_{DthCLP}) | 0.00...200 s |

DthAL1 Element

- 49 First alarm threshold $\Delta\theta_{AL1}$ (*DthAL1*) 0.3...1.0 $\Delta\theta_B$

DthAL2 Element

- 49 Second alarm threshold $\Delta\theta_{AL2}$ (*DthAL2*) 0.5...1.2 $\Delta\theta_B$

Dth> Element

- 49 Trip threshold $\Delta\theta$ (*Dth>*) 0.9...1.5 $\Delta\theta_B$

Note - The 49 protective function protection is based on RMS value measurement of three phase currents (the computed RMS value takes into account the contribution of fundamental and harmonic up to eleventh order)

— **Phase overcurrent - 50/51**

I> Element

- *I>* Curve type (*I>Curve*) DEFINITE
IEC/BS A, B, C, ANSI/IEEE MI, VI, EI
RECTIFIER, EM, I²t

- *I*_{CLP>} Activation time (*t*_{CLP>}) 0.00...200 s
- *I>* Reset time delay (*t*_{RES}) 0.00...100.0 s

Definite time

- 50/51 First threshold definite time (*I*_{>def}) 0.100...40.0 *I_n*
- *I*_{>def} within CLP (*I*_{CLP>def}) 0.100...40.0 *I_n*
- *I*_{>def} Operating time (*t*_{>def}) 0.04...200 s

Inverse time

- 50/51 First threshold inverse time (*I*_{>inv}) 0.100...20.00 *I_n*
- *I*_{>inv} within CLP (*I*_{CLP>inv}) 0.100...20.00 *I_n*
- *I*_{>inv} Operating time (*t*_{>inv}) 0.02...60.0 s

I>> Element

- *I>>* Curve type (*I>>Curve*) DEFINITE, I²t
- *I*_{CLP>>} Activation time (*t*_{CLP>>}) 0.00...200 s
- *I>>* Reset time delay (*t*_{RES}) 0.00...100.0 s

Definite time

- 50/51 Second threshold definite time (*I>>def*) 0.100...40.0 *I_n*
- *I>>def* within CLP (*I*_{CLP>>def}) 0.100...40.0 *I_n*
- *I>>def* Operating time (*t*_{>>def}) 0.03...10.00 s

Inverse time

- 50/51 Second threshold inverse time (*I>>inv*) 0.100...20.00 *I_n*
- *I>>inv* within CLP (*I*_{CLP>>inv}) 0.100...20.00 *I_n*
- *I>>inv* Operating time (*t*_{>>inv}) 0.02...10.00 s

I>>> Element

- *I*_{CLP>>>} Activation time (*t*_{CLP>>>}) 0.00...200 s
- *I>>>* Reset time delay (*t*_{RES}) 0.00...100.0 s

Definite time

- 50/51 Third threshold definite time (*I>>>def*) 0.100...40.0 *I_n*
- *I>>>def* within CLP (*I*_{CLP>>>def}) 0.100...40.0 *I_n*
- *I>>>def* Operating time (*t*_{>>>def}) 0.03...10.00 s

— **Locked rotor - 50S/51LR/14**

I_{LR>} Element

- *I*_{LRCLP>} Operating mode (*Mode 51LR>*) With/without speed contr.

Inverse time

- 51LR First threshold inverse time (*I*_{LR>inv}) 0.80...8.00 *I_B*
- Motor starting current I-MOT-ST (*I*_{MOT-ST}) 0.80...15.00 *I_B*
- *I*_{LR>inv} Operating time (*t*_{LR>inv}) 0.10...200 s

I_{LR>>} Element

- *I*_{LRCLP>>} Operating mode (*Mode 51LR>>*) With/without speed contr.
- *I*_{LRCLP>>} Activation time (*t*_{LRCLP>>def}) 0.00...200 s

Definite time

- 51LR Second threshold definite time (*I*_{LR>>def}) 0.90...8.00 *I_B*
- *I*_{LR>>def} Operating time (*t*_{LR>>def}) 0.10...200 s

Note - The mathematical formula for INVERSE curves is:

$$t = t_{LR>inv} (I_{MOT-ST} / I)^2 \text{ where:}$$

t = trip time (in seconds)

*t*_{LR>inv} = operating time setting (in seconds)

*I*_{MOT-ST} = starting current with nominal voltage

I = max phase voltage (fundamental component)

— **Residual overcurrent - 50N/51N**

I_{E>} Element

- *I_{E>}* Curve type (*I_{E>}Curve*) DEFINITE
IEC/BS A, B, C, ANSI/IEEE MI, VI, EI, EM

- *I*_{ECLP>} Activation time (*t*_{ECLP>}) 0.00...200 s
- *I_{E>}* Reset time delay (*t*_{RES}) 0.00...100.0 s

Definite time

- 50N/51N First threshold definite time (*I_{E>}def*) 0.002...10.00 *I_{En}*
- *I_{E>}def* within CLP (*I*_{ECLP>def}) 0.002...10.00 *I_{En}*
- *I_{E>}def* Operating time (*t*_{E>def}) 0.04...200 s

Inverse time

- 50N/51N First threshold inverse time (*I_{E>}inv*) 0.002...2.00 *I_{En}*
- *I_{E>}inv* within CLP (*I*_{ECLP>inv}) 0.002...2.00 *I_{En}*
- *I_{E>}inv* Operating time (*t*_{E>inv}) 0.02...60.0 s

I_{E>>} Element

- *I*_{ECLP>>} Activation time (*t*_{ECLP>>}) 0.00...200 s
- *I_{E>>}* Reset time delay (*t*_{E>>RES}) 0.00...100.0 s

Definite time

- 50N/51N Second threshold definite time (*I_{E>>def}*) 0.010...10.00 *I_{En}*
- *I_{E>>def}* within CLP (*I*_{ECLP>>def}) 0.010...10.00 *I_{En}*
- *I_{E>>def}* Operating time (*t*_{E>>def}) 0.03...10.00 s

I_{E>>>} Element

- *I*_{ECLP>>>} Activation time (*t*_{ECLP>>>}) 0.00...200 s
- *I_{E>>>}* Reset time delay (*t*_{E>>>RES}) 0.00...100.0 s

Definite time

- 50N/51N Third threshold definite time (*I_{E>>>def}*) 0.010...10.00 *I_{En}*
- *I_{E>>>def}* within CLP (*I*_{ECLP>>>def}) 0.010...10.00 *I_{En}*
- *I_{E>>>def}* Operating time (*t*_{E>>>def}) 0.03...10.00 s

— **Minimum power factor - 55**

CPhi< Element

- CB55 delay (*t*_{ARM-CPhi<}) 0.07...300 s

Definite time

- CPhiLAG< First threshold definite time (*CPhiLAG<*) 0.1...0.9
- CPhiLAG< Operating time (*t*_{CPhiLAG<}) 0.04...100.0 s
- CPhiLEAD< First threshold definite time (*CPhiLEAD<*) 0.1...0.9
- CPhiLEAD< Operating time (*t*_{CPhiLEAD<}) 0.04...100.0 s

— **Overtoltage - 59**

Common configuration:

- Voltage measurement type for 59 (*U*_{type59})^[1] *U_{ph-ph}/U_{ph-n}*
- 59 Operating logic (*Logic59*) AND/OR

U> Element

- *U>* Curve type (*U>Curve*) DEFINITE or INVERSE^[2]

Definite time

- 59 First threshold definite time (*U>def*) 0.50...1.50 *U_n/E_n*
- *U>def* Operating time (*t*_{U>def}) 0.03...100.0 s

Inverse time

- 59 First threshold inverse time (*U>inv*) 0.50...1.50 *U_n/E_n*
- *U>inv* Operating time (*t*_{U>inv}) 0.10...100.0 s

U>> Element

Definite time

- 59 Second threshold definite time (*U>>def*) 0.50...1.50 *U_n/E_n*
- *U>>def* Operating time (*t*_{U>>def}) 0.03...100.0 s

Note [1] - With *U_{ph-ph}* setting all threshold are in p.u. *U_n*

With *U_{ph-n}* setting all threshold are in p.u. *E_n*

Note [2] - The mathematical formula for INVERSE curves is:

$$t = 0.5 \cdot t_{U>inv} / [(U/U_{>inv}) - 1], \text{ where:}$$

t = trip time (in seconds)

*t*_{U>inv} = operating time setting (in seconds)

U = input voltage

*U*_{>inv} = threshold setting

— **Residual overvoltage - 59N**

Common configuration:

- Residual voltage measurement for 59N- direct/calc. *U_E/U_{EC}*
- 59N Operating mode from 74VT internal (*74VTint59N*) OFF/Block
- 59N Operating mode from 74VT external (*74VText59N*) OFF/Block

U_{E>} Element

- *U_{E>}* Curve type (*U_{E>}Curve*) DEFINITE OR INVERSE^[1]
- *U_{E>}* Reset time delay (*t*_{E>RES}) 0.00...100.0 s

Definite time

- 59N First threshold definite time (*U_{E>}def*) 0.01...0.70 *U_{En}*
- *U_{E>}def* Operating time (*t*_{E>def}) 0.07...100.0 s

Inverse time

- 59N First threshold inverse time (*U_{E>}inv*) 0.01...0.50 *U_{En}*
- *U_{E>}inv* Operating time (*t*_{E>inv}) 0.10...100.0 s

$U_{E>>}$ Element

- $U_{E>>}$ Reset time delay ($t_{U_{E>>RES}}$) 0.00...100.0 s
- 59N Second threshold definite time ($U_{E>>def}$) 0.01...0.70 U_{En}
- $U_{E>>def}$ Operating time ($t_{U_{E>>def}}$) 0.07...100.0 s

Note [1] - The mathematical formula for INVERSE curves is:

$$t = 0.5 \cdot t_{U_{E>inv}} / ((U_E / U_{E>inv}) - 1) \text{ where:}$$

t = trip time (in seconds)

$t_{U_{E>inv}}$ = operating time setting (in seconds)

U_E = residual input voltage

$U_{E>inv}$ = threshold setting

— Negative sequence overvoltage - 59V2

U_2 Element

Definite time

- 59V2 First threshold definite time ($U_{2>def}$) 0.01...0.50 U_n
- $U_{2>def}$ Operating time ($t_{U_{2>def}}$) 0.07...100.0 s

— Maximum number of startings (Restart inhibition) - 66

- Operating mode (Type66) NST/TST
- Control window (t_c) 1...60 min
- N_{ST} (Starts inside t_c) 1...30
- T_{ST} (Cumulative start time inside t_c) 1...600 s
- 66 Inhibition time (t_{1N}) 0...60 min

— Ground directional overcurrent - 67N

Common configuration:

- 67N Operating mode (Mode67N) $||I \cdot \cos$
- Residual voltage measurement type for 67N - direct/calculated (3VoType67N) U_E / U_{EC}
- 67N Multiplier of threshold for insensitive zone (M) 1.5...10.0
- 67N Operating mode from 74VT internal (74VTint67N) OFF/Block/Not directional
- 67N Operating mode from 74VT external (74VText67N) OFF/Block/Not directional

I_{ED} Element

- I_{ED} Curve type DEFINITE IEC/BS A, B, C, ANSI/IEEE MI, VI, EI, EM
- I_{EDCLP} Activation time (t_{EDCLP}) 0.00...100.0 s
- I_{ED} Reset time delay (t_{EDRES}) 0.00...100.0 s

Definite time

- 67N First threshold definite time ($I_{ED>def} - U_{ED>def}$)
- Residual current pickup value 0.002...10.00 I_{En}
- Residual voltage pickup value 0.004...0.500 U_{En}
- Characteristic angle 0...359°
- Half operating sector 1...180°
- $I_{ED>def}$ within CLP ($I_{EDCLP>def}$) 0.002...10.00 I_{En}
- $I_{ED>def}$ Operating time ($t_{ED>def}$) 0.05...200 s

Inverse time

- 67N First threshold inverse time ($I_{ED>inv} - U_{ED>inv}$)
- Residual current pickup value 0.002...2.00 I_{En}
- Residual voltage pickup value 0.004...0.500 U_{En}
- Characteristic angle 0...359°
- Half operating sector 1...180°
- $I_{ED>inv}$ within CLP ($I_{EDCLP>inv}$) 0.002...2.00 I_{En}
- $I_{ED>inv}$ Operating time ($t_{ED>inv}$) 0.02...60.0 s

$I_{ED>>}$ Element

- $I_{ED>>}$ Curve type ($I_{ED>>Curve}$) DEFINITE IEC/BS A, B, C, ANSI/IEEE MI, VI, EI, EM
- $I_{EDCLP>>}$ Activation time ($t_{EDCLP>>}$) 0.00...100.0 s
- $I_{ED>>}$ Reset time delay ($t_{ED>>RES}$) 0.00...100.0 s

Definite time

- 67N Second threshold definite time ($I_{ED>>def} - U_{ED>>def}$)
- Residual current pickup value 0.002...10.00 I_{En}
- Residual voltage pickup value 0.004...0.500 U_{En}
- Characteristic angle 0...359°
- Half operating sector 1...180°
- $I_{ED>>def}$ within CLP ($I_{EDCLP>>def}$) 0.002...10.00 I_{En}
- $I_{ED>>def}$ Operating time ($t_{ED>>def}$) 0.05...10.00 s

Inverse time

- 67N Second threshold inverse time ($I_{ED>>inv} - U_{ED>>inv}$)
- Residual current pickup value 0.002...2.00 I_{En}
- Residual voltage pickup value 0.004...0.500 U_{En}
- Characteristic angle 0...359°
- Half operating sector 1...180°
- $I_{ED>>inv}$ within CLP ($I_{EDCLP>>inv}$) 0.002...2.00 I_{En}
- $I_{ED>>inv}$ Operating time ($t_{ED>>inv}$) 0.02...10.00 s

$I_{ED>>>}$ Element

- $I_{EDCLP>>>}$ Activation time ($t_{EDCLP>>>}$) 0.00...100.0 s
- $I_{ED>>>}$ Reset time delay ($t_{ED>>>RES}$) 0.00...100.0 s

Definite time

- 67N Third threshold definite time ($I_{ED>>>def} - U_{ED>>>def}$)
- Residual current pickup value 0.002...10.00 I_{En}
- Residual voltage pickup value 0.004...0.500 U_{En}
- Characteristic angle 0...359°
- Half operating sector 1...180°
- $I_{ED>>>def}$ within CLP ($I_{EDCLP>>>def}$) 0.002...10.00 I_{En}
- $I_{ED>>>def}$ Operating time ($t_{ED>>>def}$) 0.05...10.00 s

$I_{ED>>>>}$ Element

- $I_{EDCLP>>>>}$ Activation time ($t_{EDCLP>>>>}$) 0.00...100.0 s
- $I_{ED>>>>}$ Reset time delay ($t_{ED>>>>RES}$) 0.00...100.0 s

Definite time

- 67N Fourth threshold definite time ($I_{ED>>>>def} - U_{ED>>>>def}$)
- Residual current pickup value 0.002...10.00 I_{En}
- Residual voltage pickup value 0.004...0.500 U_{En}
- Characteristic angle 0...359°
- Half operating sector 1...180°
- $I_{ED>>>>def}$ within CLP ($I_{EDCLP>>>>def}$) 0.002...10.00 I_{En}
- $I_{ED>>>>def}$ Operating time ($t_{ED>>>>def}$) 0.05...10.00 s

— Overfrequency - 81O

$f>$ Element

Definite time

- 81O First threshold definite time ($f>_{def}$) 1.000...1.200 f_n
- $f>_{def}$ Operating time ($t_{f>def}$) 0.05...100.00 s

$f>>$ Element

Definite time

- 81O Second threshold definite time ($f>>_{def}$) 1.000...1.200 f_n
- $f>>_{def}$ Operating time ($t_{f>>def}$) 0.05...100.00 s

— Underfrequency - 81U

$f<$ Element

Definite time

- 81U First threshold definite time ($f<_{def}$) 0.800...1.000 f_n
- $f<_{def}$ Operating time ($t_{f<def}$) 0.07...100.0 s

$f<<$ Element

Definite time

- 81U Second threshold definite time ($f<<_{def}$) 0.800...1.000 f_n
- $f<<_{def}$ Operating time ($t_{f<<def}$) 0.07...100.0 s

— Breaker failure - BF

- BF Phase current threshold ($I_{BF>}$) 0.05...1.00 I_n
- BF Residual current threshold ($I_{BF<}$) 0.01...2.00 I_{En}
- BF Time delay (t_{BF}) 0.06...10.00 s

— CT supervision - 74CT

- 74CT Threshold ($S<$) 0.10...0.95
- 74CT Overcurrent threshold (I^*) 0.10...1.00 I_n
- $S<$ Operating time ($t_{S<}$) 0.03...200 s

— VT supervision - 74VT

- 74VT Negative sequence overvoltage threshold ($U_{2VT>}$) 0.05...0.50 E_n
- 74VT Negative sequence overvoltage threshold ($I_{2VT>}$) 0.05...0.50 I_n
- 74VT Phase undervoltage threshold ($U_{VT<}$) 0.05...0.50 E_n
- 74VT Minimum change of current threshold 74VT ($D_{IVT<}$) 0.05...0.50 I_n
- 74VT Undercurrent inhibition threshold ($I_{VT<}$) 0.100...40.0 I_n
- 74VT Alarm time delay (t_{VT-AL}) 0.0...10.0 s

— Selective block - BLOCK2

Selective block IN:

- BLIN Max activation time for phase protections (t_{B-IPh}) 0.10...10.00 s
- BLIN Max activation time for ground protections (t_{B-IE}) 0.10...10.00 s

Selective block OUT:

- BLOUT Dropout time delay for phase protections (t_{F-IPh}) 0.00...1.00 s
- BLOUT Drop-out time delay for ground protections (t_{F-IE}) 0.00...1.00 s
- BLOUT Drop-out time delay for phase and ground protections ($t_{F-IPh/IE}$) 0.00...1.00 s

— Circuit Breaker supervision

| | |
|--|------------------------------------|
| • Number of CB trips (<i>N.Open</i>) | 0...10000 |
| • Cumulative CB tripping currents (<i>SumI</i>) | 0...5000 I_n |
| • CB opening time for I^2t calculation (t_{break}) | 0.05...1.00 s |
| • Cumulative CB tripping I^2t (<i>SumI^2t</i>) | 0...5000 (I_n) ² ·s |
| • CB max allowed opening time ($t_{break>}$) | 0.05...1.00 s |

— Pilot wire diagnostic

| | |
|--|---------------------------|
| BLOUT1 Diagnostic pulses period (<i>PulseBLOUT1</i>) | OFF - 0.1-1-5-10-60-120 s |
|--|---------------------------|

METERING & RECORDING

— Measured parameters

Direct:

| | |
|------------------------------------|-----------------------------------|
| • Frequency | f |
| • Fundamental RMS phase currents | I_{L1}, I_{L2}, I_{L3} |
| • True RMS phase currents (1) | $I_{L1rms}, I_{L2rms}, I_{L3rms}$ |
| • Fundamental RMS residual current | I_E |
| • Fundamental RMS input voltages | U_{L1}, U_{L2}, U_{L3} |
| • Fundamental RMS residual voltage | U_E |

Note [1] - the computed RMS value takes into account the contribution of fundamental and harmonic up to eleventh order

Calculated:

| | |
|---|--------------------------|
| • Thermal image | $D\theta$ |
| • Phase-to-phase voltages | U_{12}, U_{23}, U_{31} |
| • Fundamental RMS calculated residual voltage | U_{EC} |
| • Fundamental RMS calculated residual current | I_{EC} |
| • Maximum current between $I_{L1}-I_{L2}-I_{L3}$ | I_{Lmax} |
| • Maximum current between $I_{L1rms}, I_{L2rms}, I_{L3rms}$ | $I_{Lmax-rms}$ |
| • Minimum current between $I_{L1}-I_{L2}-I_{L3}$ | I_{Lmin} |
| • Minimum current between $I_{L1rms}, I_{L2rms}, I_{L3rms}$ | $I_{Lmin-rms}$ |
| • Average current between $I_{L1}-I_{L2}-I_{L3}$ | I_L |
| • Average current between $I_{L1rms}, I_{L2rms}, I_{L3rms}$ | I_{L-rms} |
| • Maximum voltage between $U_{L1}-U_{L2}-U_{L3}$ | U_{Lmax} |
| • Average voltage between $U_{L1}-U_{L2}-U_{L3}$ | U_L |
| • Maximum voltage between $U_{12}-U_{23}-U_{31}$ | U_{max} |
| • Average voltage between $U_{12}-U_{23}-U_{31}$ | U |

Phase:

| | |
|--|--------------|
| • Displacement angle of I_{L1} respect to U_{L1} | Φ_{iL1} |
| • Displacement angle of I_{L2} respect to U_{L2} | Φ_{iL2} |
| • Displacement angle of I_{L3} respect to U_{L3} | Φ_{iL3} |
| • Displacement angle of U_E respect to I_E | Φ_{iE} |
| • Displacement angle of U_{EC} respect to I_E | Φ_{iEC} |

Sequence:

| | |
|-----------------------------|-------|
| • Positive sequence current | I_1 |
| • Negative sequence current | I_2 |
| • Positive sequence voltage | U_1 |
| • Negative sequence voltage | U_2 |

Power:

| | |
|-------------------------|--|
| • Total active power | P |
| • Total reactive power | Q |
| • Total apparent power | S |
| • Power factor | $\cos\Phi$ |
| • Phase active powers | P_{L1}, P_{L2}, P_{L3} |
| • Phase reactive powers | Q_{L1}, Q_{L2}, Q_{L3} |
| • Power factors | $\cos\Phi_{iL1}, \cos\Phi_{iL2}, \cos\Phi_{iL3}$ |

Impedance:

| | |
|---|--------------|
| • L1 phase impedance (40 element) | Z_{L1} |
| • Resistive component of the L1 phase impedance | $\pm R_{L1}$ |
| • Reactive component of the L1 phase impedance | $\pm X_{L1}$ |

Start:

| | |
|--------------------|-------------|
| • Number of starts | N_{Start} |
| • Time of starts | T_{Start} |

Demand phase:

| | |
|---------------------------------|-----------------------------------|
| • Phase fixed currents demand | $I_{L1FIX}, I_{L2FIX}, I_{L3FIX}$ |
| • Phase rolling currents demand | $I_{L1ROL}, I_{L2ROL}, I_{L3ROL}$ |
| • Phase peak currents demand | $I_{L1MAX}, I_{L2MAX}, I_{L3MAX}$ |
| • Phase minimum currents demand | $I_{L1MIN}, I_{L2MIN}, I_{L3MIN}$ |

Demand power:

| | |
|---------------------------------|-----------|
| • Fixed active power demand | P_{FIX} |
| • Fixed reactive power demand | Q_{FIX} |
| • Rolling active power demand | P_{ROL} |
| • Rolling reactive power demand | Q_{ROL} |
| • Peak active power demand | P_{MAX} |
| • Peak reactive power demand | Q_{MAX} |
| • Minimum active power demand | P_{MIN} |
| • Minimum reactive power demand | Q_{MIN} |

Energy:

| | |
|----------------------------|----------|
| • Positive active energy | E_{A+} |
| • Negative active energy | E_{A-} |
| • Total active energy | E_A |
| • Positive reactive energy | E_{Q+} |
| • Negative reactive energy | E_{Q-} |
| • Total reactive energy | E_Q |

Motor state:

| | |
|--------------------------------|------------|
| • Operating time counter | P_{-RMT} |
| • Total operating time counter | T_{-RMT} |

Temperature

| | |
|-------------------------|--------------|
| • Pt1...Pt8 diagnostic | ON/LOW/HIGH |
| • Pt1...Pt8 temperature | -40...240 °C |

— Event recording (SER)

| | |
|------------------|----------|
| Number of events | 300 |
| Recording mode | circular |

Trigger:

| | |
|---|---------------------|
| • Start/Trip of enabled protection or control element | |
| • Binary inputs switching (OFF/ON or ON/OFF) | IN1...INx |
| • Setting changes | |
| • Auxiliary supply | Power UP/Power DOWN |

Data recorded:

| | |
|-------------------------------------|---|
| • Counter (resettable by ThySetter) | 0...10 ⁹ |
| • Cause | binary input/trip/setting change/Power ON/OFF |
| • Time stamp | Date and time |

— Fault recording (SFR)

| | |
|------------------|----------|
| Number of faults | 20 |
| Recording mode | circular |

Trigger:

| | |
|---|-----------|
| • Output relays of enabled protection or control element (OFF-ON) | |
| • External trigger (binary inputs) | IN1...INx |

Data recorded:

| | |
|---|---|
| • Counter (resettable by ThySetter) | 0...10 ⁹ |
| • Time stamp | Date and time |
| • Cause | tripped element |
| • Fundamental RMS phase currents | $I_{L1r}, I_{L2r}, I_{L3r}$ |
| • True RMS phase currents | $I_{L1rms-r}, I_{L2rms-r}, I_{L3rms-r}$ |
| • Fundamental RMS residual current | I_{Er} |
| • Fundamental RMS phase voltages | $U_{L1r}, U_{L2r}, U_{L3r}$ |
| • Fundamental RMS phase-to-phase voltages | $U_{12r}, U_{23r}, U_{31r}$ |
| • Fundamental RMS residual voltages (measured and calculated) | U_{Er}, U_{EC} |
| • Displacement angles ($I_{L1}-U_{L1}, I_{L2}-U_{L2}, I_{L3}-U_{L3}$) | $\Phi_{iL1r}, \Phi_{iL2r}, \Phi_{iL3r}$ |
| • Displacement angles (U_E-I_E) and ($U_{EC}-I_E$) | Φ_{iEr}, Φ_{iECr} |
| • Negative sequence current | I_{2r} |
| • Positive and negative sequence voltages | U_{1r}, U_{2r} |
| • Total active and reactive powers | P_r, Q_r |
| • Power factor | $\cos\Phi_{ir}$ |
| • Resistive component of the L1 phase impedance | $\pm R_{L1r}$ |
| • Reactive component of the L1 phase impedance | $\pm X_{L1r}$ |
| • Thermal image | $D\theta$ |
| • Number of starts | $N_{Start-r}$ |
| • Time of starts | $T_{Start-r}$ |
| • Binary inputs state | IN1, IN2...INx |
| • Output relays state | K1...K6...K10 |
| • Fault cause info (operating phase) | L1, L2, L3 |

— Digital Fault Recorder (Oscillography)

| | |
|---|-------------------------------|
| File format | COMTRADE |
| Records | depending on setting [1] |
| Recording mode | circular |
| Sampling rate | 24 sample/cycle |
| Trigger setup: | |
| • Pre-trigger time | 0.05...1.00 s |
| • Post-trigger time | 0.05...60.00 s |
| • Trigger from inputs | IN1, IN2...INx |
| • Trigger from outputs | K1...K6...K10 |
| • Communication | ThySetter |
| Set sample channels: | |
| • Instantaneous currents | $i_{L1}, i_{L2}, i_{L3}, i_E$ |
| • Instantaneous voltages | $u_{L1}, u_{L2}, u_{L3}, u_E$ |
| Set analog channels (Analog 1...12): | |
| • Frequency | f |
| • Fundamental RMS phase currents | I_{L1}, I_{L2}, I_{L3} |
| • True RMS phase currents | I_{L1}, I_{L2}, I_{L3} |
| • Fundamental RMS positive and negative sequence currents | I_1, I_2 |
| • Fundamental RMS residual currents (measured and calc.) | I_E, I_{EC} |
| • Fundamental RMS phase voltages | U_{L1}, U_{L2}, U_{L3} |
| • Fundamental RMS phase-to-phase voltages | U_{12}, U_{23}, U_{31} |
| • Fundamental RMS residual voltage | U_E |
| • Fundamental RMS calculated residual voltage | U_{EC} |
| • Active total Power | P |
| • Rective total Power | Q |
| • Power factor | $cosPhi$ |

| | |
|---|--------------------------------------|
| • Phase Active Powers | $\pm P_{L1}, \pm P_{L2}, \pm P_{L3}$ |
| • Phase Reactive Powers | $\pm Q_{L1}, \pm Q_{L2}, \pm Q_{L3}$ |
| • Phase Power factors | $cosPhiL1, cosPhiL2, cosPhiL3$ |
| • Resistive component of the L1 phase impedance | $\pm R_{L1}$ |
| • Reactive component of the L1 phase impedance | $\pm X_{L1}$ |
| • L1 phase impedance (40 element) | Z_{L1} |
| • Displacement angle (U_E-I_E) | $PhiE$ |
| • Displacement angle ($U_{EC}-I_E$) | $PhiEC$ |
| • Thermal image | $\Delta\theta$ |

Set digital channels (Digital 1...12):

| | |
|-----------------------|----------------|
| • Output relays state | K1...K6...K10 |
| • Binary inputs state | IN1, IN2...INx |

Note [1] - For instance, with following setting:

- Pre-trigger time and Post-trigger time 0.25 s
 - Sampled channels $i_{L1}, i_{L2}, i_{L3}, i_E, u_{L1}, u_{L2}, u_{L3}, u_E$
 - Analog channels $I_{L1}, I_{L2}, I_{L3}, I_{L1rms}, I_{L2rms}, I_{L3rms}, I_E, I_1, I_2, U_1, U_2$
 - Digital channels K1, K2, K3, K4, K5, K6, IN1, IN2
- up to 100 records can be stored with $f = 50$ Hz

Oscillography (DFR)

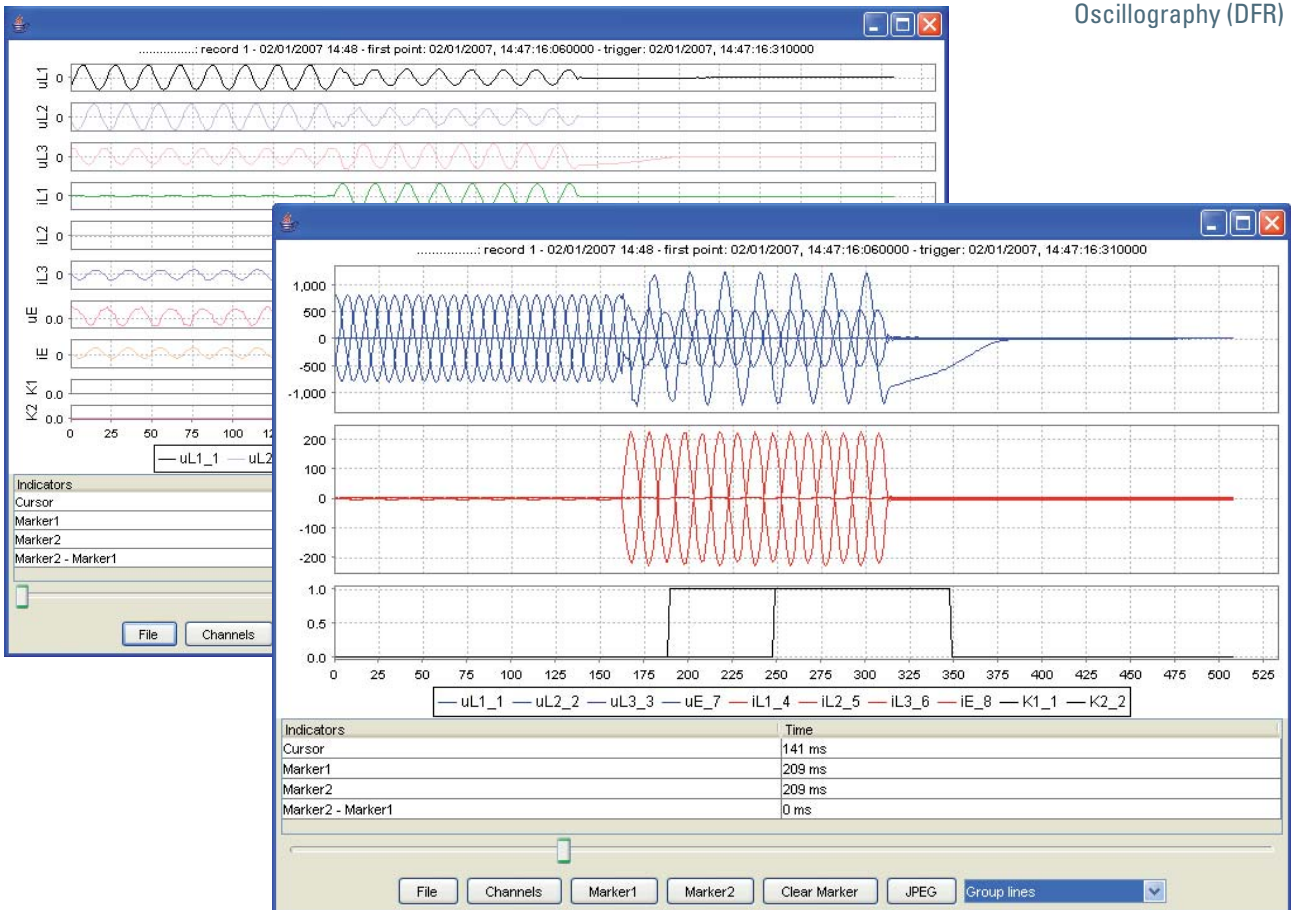

— Connection diagram example

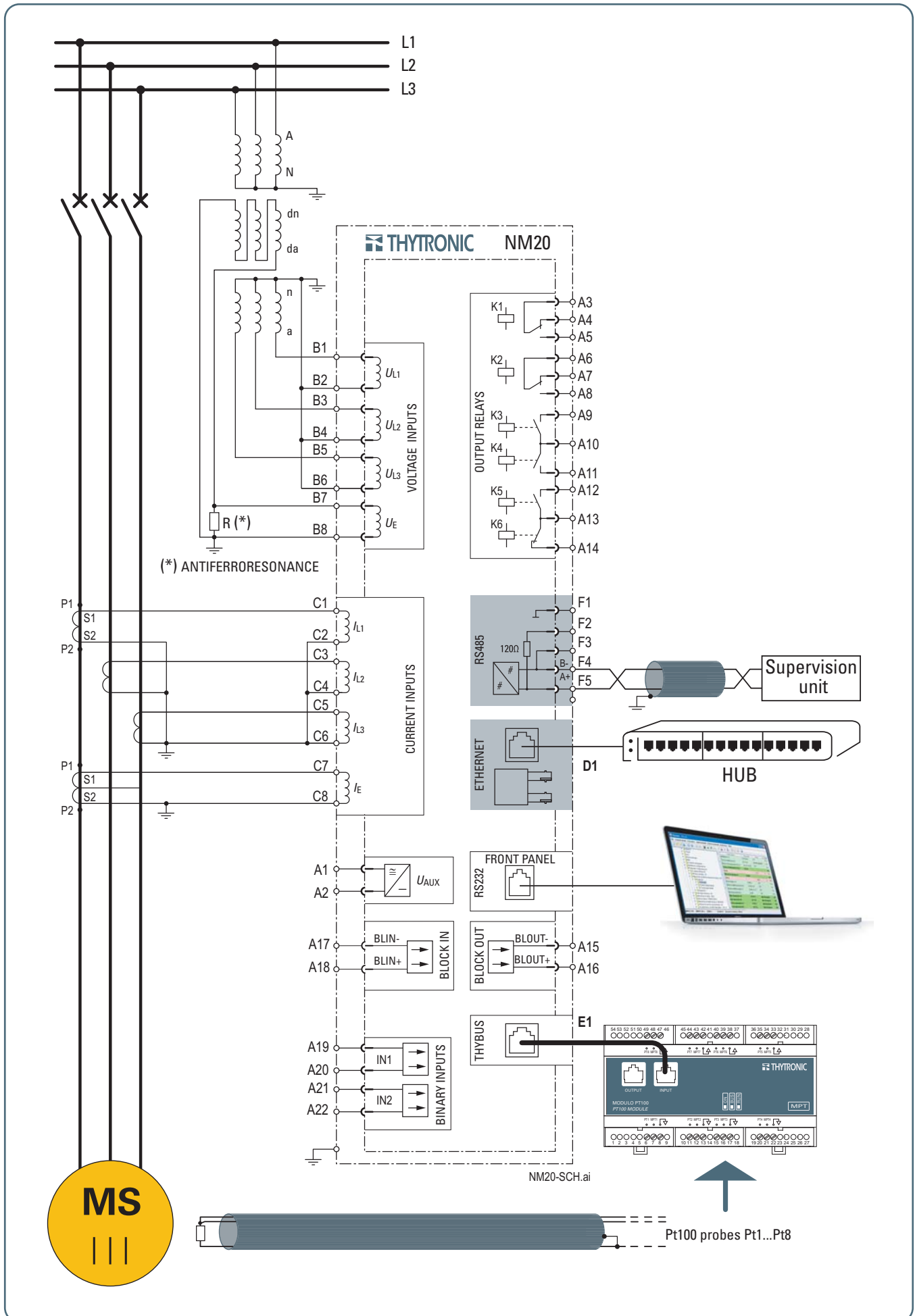

DIMENSIONS

FRONT VIEW

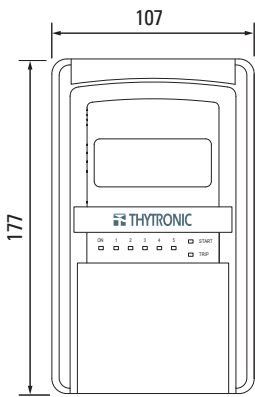

FLUSH MOUNTING

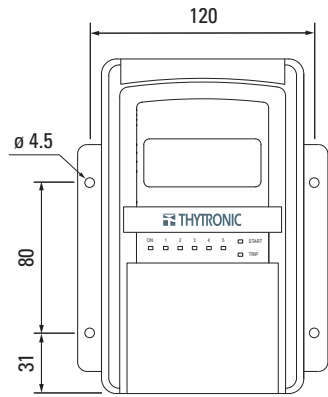

PROJECTING MOUNTING

REAR VIEW

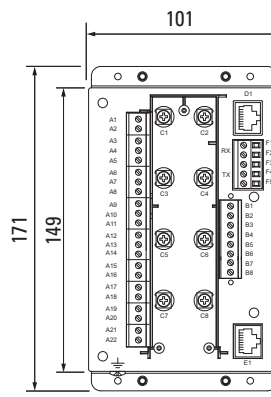

FLUSH MOUNTING

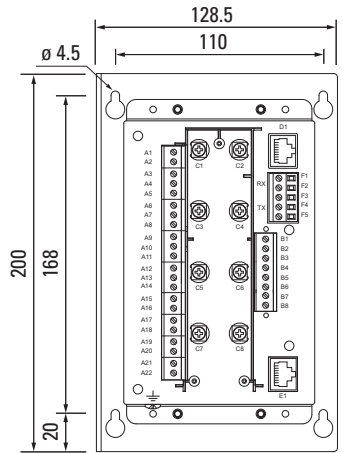

PROJECTING MOUNTING
(Separate operator panel)

SIDE VIEW

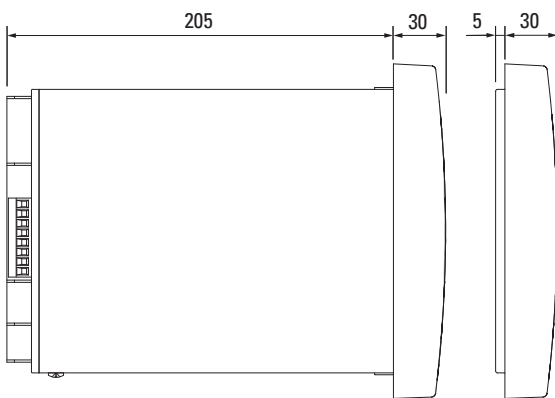

FLUSH MOUNTING



SEPARATE OPERATOR PANEL

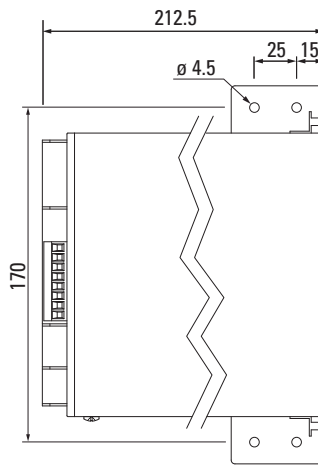

PROJECTING MOUNTING
(Separate operator panel)

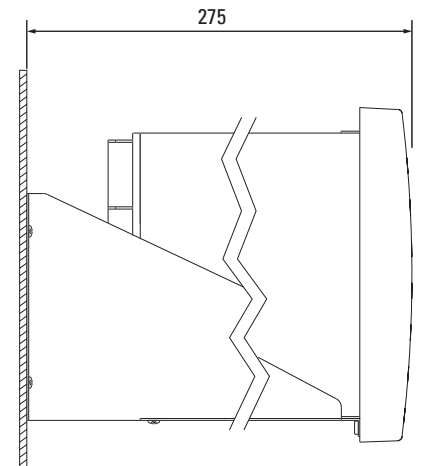

PROJECTING MOUNTING
(Stand alone)

RACK MOUNTING

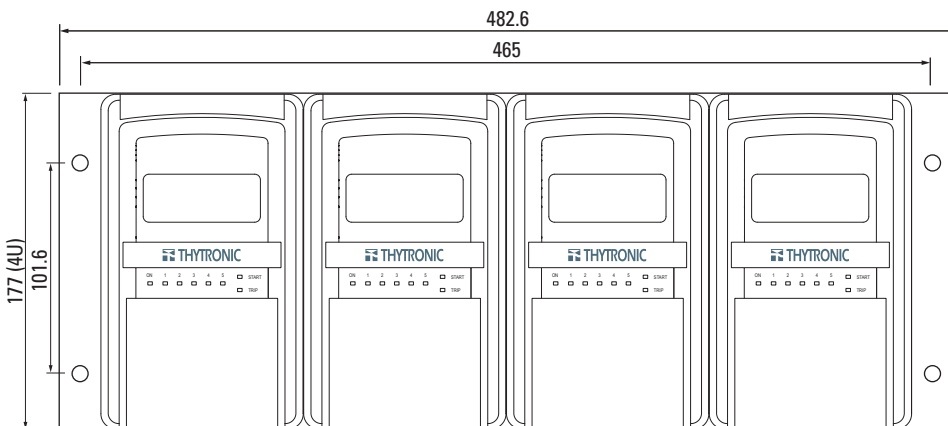

FLUSH MOUNTING CUTOUT

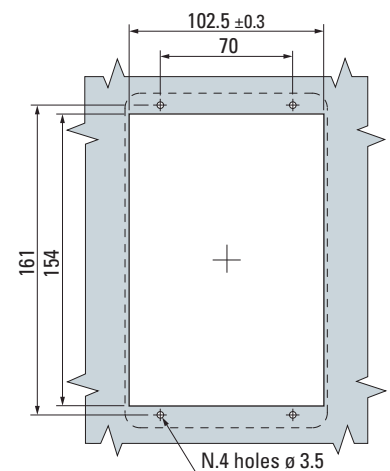

www.thytronic.it



A PERSONALISED SERVICE OF THE PRODUCTION, A RAPID DELIVERY, A COMPETITIVE PRICE AND AN ATTENTIVE EVALUATION OF OUR CUSTOMERS NEEDS, HAVE ALL CONTRIBUTED IN MAKING US ONE OF THE BEST AND MOST RELIABLE PRODUCERS OF PROTECTIVE RELAYS. FORTY YEARS OF EXPERIENCE HAS MADE STANDARD THESE ADVANTAGES THAT ARE GREATLY APPRECIATED BY LARGE COMPANIES THAT DEAL ON THE INTERNATIONAL MARKET. A HIGHLY QUALIFIED AND MOTIVATED STAFF PERMITS US TO OFFER AN AVANT-GARDE PRODUCT AND SERVICE WHICH MEET ALL SAFETY AND CONTINUITY DEMANDS, VITAL IN THE GENERATION OF ELECTRIC POWER. OUR COMPANY PHILOSOPHY HAS HAD A POSITIVE REACTION FROM THE MARKET BY BACKING OUR COMMITMENT AND HENCE STIMULATING OUR GROWTH.