



THYTRONIC

PRON

Protection Relays



NA20

FEEDER PROTECTION RELAY

THE BASIC SOLUTION FOR FEEDERS AND TRANSFORMERS PROTECTION WITH THERMAL IMAGE AND NEGATIVE SEQUENCE CURRENT ELEMENTS

— Application

The relay type NA20 is typically used in HV, MV and LV radial networks as feeder or power transformer protection.

In solidly grounded systems the residual overcurrent protection can be used on feeders of any length, while in ungrounded or Petersen coil and/or resistance grounded systems, the residual overcurrent protection can be used on feeders of small length in order to avoid unwanted trippings due to the capacitive current contribution of the feeder on external ground fault.

Beside to the phase and residual overcurrent protection, the following protective functions are provided:

- Thermal image protection of lines and power transformers.
- Undercurrent protection for monitoring of CB opening.
- Negative sequence protection against asymmetrical short circuits and unbalance loads.
- I_2/I_1 protection against phase interruption under low-load condition.

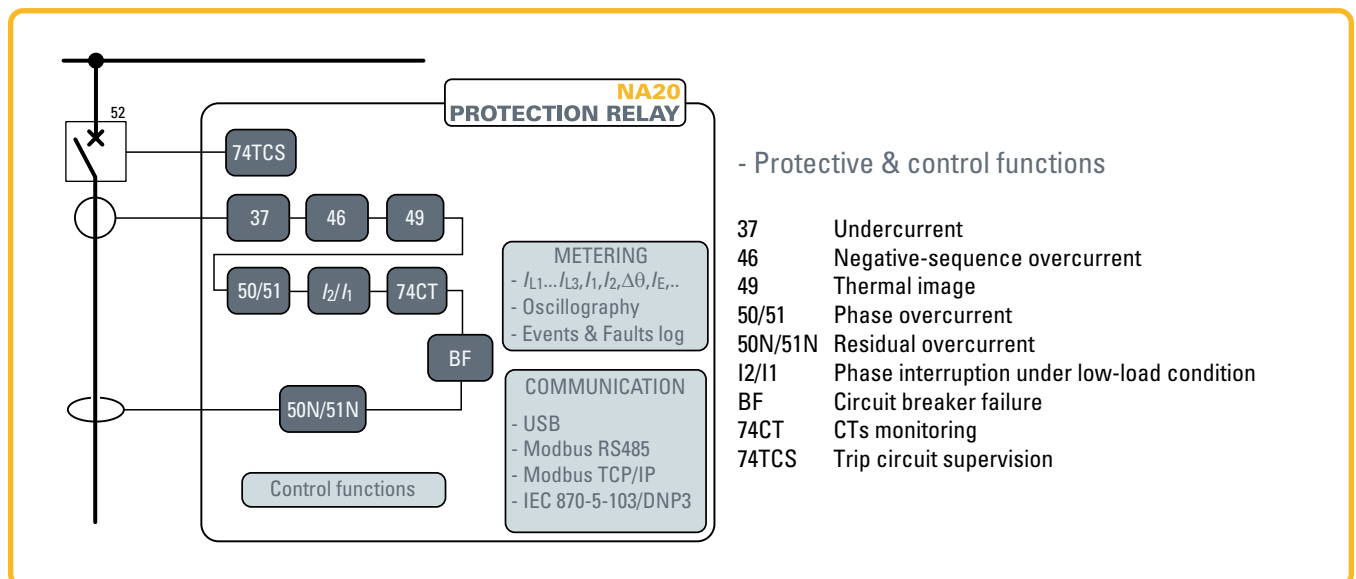

— **Measuring inputs**

Three phase current inputs and one residual current input, with nominal currents independently selectable at 1 A or 5 A through DIP-switches.

— **Firmware updating**

The use of flash memory units allows on-site firmware updating.

— **Two set point profiles (A,B)**

Two independent groups of settings are provided. Switching from profiles may be operated by means of MMI, binary input and communication.

— **Construction**

According to the hardware configurations, the NA20 protection relay can be shipped in various case styles depending on the required mounting options (flush, projecting mounting, rack or with separate operator panel).

— **Modular design**

In order to extend I/O capability, the NA20 hardware can be customized through external auxiliary modules:

- MRI - Output relays and LEDs
- MID16 - Binary inputs
- MCI - 4...20 mA converter
- MPT - Pt100 probe inputs



— **Binary inputs**

Two or five binary inputs are available with programmable active state (active-ON/active-OFF) and programmable timer (active to OFF/ON or ON/OFF transitions). Several presettable functions can be associated to each input.

— **Blocking input/outputs**

One output blocking circuit and one input blocking circuit are provided.

The output blocking circuits of one or several Pro_N relays, shunted together, must be connected to the input blocking circuit of the protection relay, which is installed upwards in the electric plant. The output circuit works as a simple contact, whose condition is detected by the input circuit of the upwards protection relay.

For long distances, when high insulation and high EMC immunity is essential, a suitable pilot wire to fiber optic converter (BFO) is available.

— **Output relays**

Six output relays are available (two changeover, three make and one break contacts); each relay may be individually programmed as normal state (normally energized, de-energized or pulse) and reset mode (manual or automatic).

A programmable timer is provided for each relay (minimum pulse width). The user may program the function of each relay in accordance with a matrix (tripping matrix) structure.

— **MMI (Man Machine Interface)**

The user interface comprises a membrane keyboard, a backlight LCD alphanumeric display and eight LEDs. The green ON LED indicates auxiliary power supply and self diagnostics, two LEDs are dedicated to the Start and Trip (yellow for Start, red for Trip) and five red LEDs are user assignable.



— **Communication**

Multiple communication interfaces are implemented:

- One USB local communication front-end interface for communication with ThyVisor setup software.
- Two back-end interfaces for communication with remote monitoring and control systems by:
 - RS485 port using ModBus® RTU, IEC 60870-5-103 or DNP3 protocol,
 - Ethernet port (RJ45 or optical fiber) using ModBus/TCP protocol.

— **Programming and settings**

All relay programming and adjustment operations may be performed through MMI (Keyboard and display) or using a Personal Computer with the aid of the ThyVisor software.

The same PC setup software is required to set, monitor and configure all Pro_N devices.

Full access to the available data is provided:

- Read status and measures.
- Read/edit settings (on-line or off-line edit).

Two session level (User or Administrator) with password for sensible data access are provided.

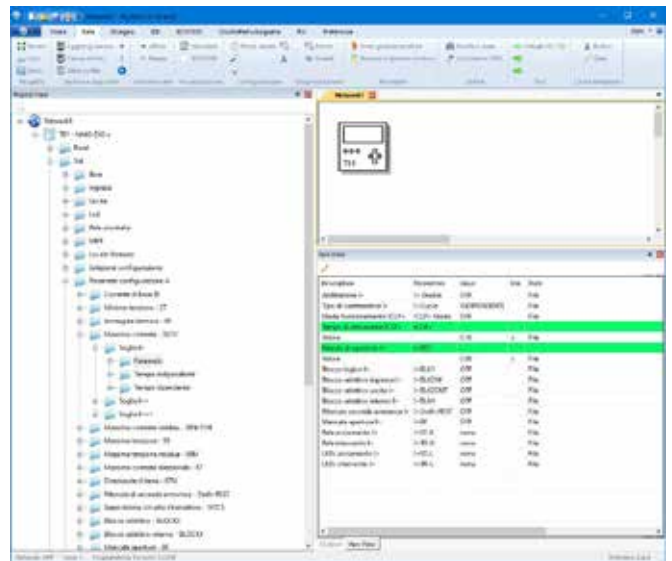

— **Control and monitoring**

Several predefined functions are implemented:

- Circuit Breaker commands and diagnostic
- Activation of two set point profiles
- Phase CTs monitoring (74CT)
- Logic selectivity
- Cold load pickup (CLP) with block or setting change
- Trip circuit supervision (74TCS)
- Second harmonic restraint (inrush)
- Remote tripping.

User defined logic may be customized according to IEC 61131-3 standard protocol (PLC).

Circuit Breaker commands and diagnostic

Several diagnostic, monitoring and control functions are provided:

- Health thresholds can be set; when the accumulated duty (ΣI or ΣI^2t), the number of operations or the opening time exceeds the threshold an alarm is activated.
- Breaker failure (BF); breaker status is monitored by means 52a-52b and/or through line current measurements.
- Trip Circuit Supervision (74TCS).
- Breaker control; opening and closing commands can be carried out locally or remotely.

Cold Load Pickup (CLP)

The Cold Load Pickup feature can operate in two following modes:

- Each protective element can be blocked for a adjustable time.
- Each threshold can be increased for a programmable time.

It is triggered by the circuit breaker closing.

Second harmonic restraint

To prevent unwanted tripping of the protective functions on transformer inrush current, the protective elements can be blocked when the ratio between the second harmonic current and the relative fundamental current is larger than a user programmable threshold.

The function can be programmed to switch an output relay so as to cause a blocking protection relays lacking in second harmonic restraint.

Logic selectivity

With the aim of providing a fast selective protection system some protective functions may be blocked (pilot wire accelerated logic). To guarantee maximum fail-safety, the relay performs a run time monitoring for pilot wire continuity and pilot wire shorting. Exactly the output blocking circuit periodically produces a pulse, having a small enough width in order to be ignored as an effective blocking signal by the input blocking circuit of the upwards protection, but suitable to prove the continuity of the pilot wire. Furthermore a permanent activation (or better, with a duration longer than a preset time) of the blocking signal is identified, as a warning for a possible short circuit in the pilot wire or in the output circuit of the downstream protection.

The logic selectivity function can be realized through any combination of binary inputs, output relays and/or committed pilot wires circuits.

— **Self diagnostics**

All hardware and software functions are repeatedly checked and any anomalies reported via display messages, communication interfaces, LEDs and output relays.

Anomalies may refer to:

- Hw faults (auxiliary power supply, output relay coil interruptions, MMI board...).
- Sw faults (boot and run time tests for data base, EEPROM memory checksum failure, data BUS,...).
- Pilot wire faults (break or short in the wire).
- Circuit breaker faults.

— **Metering**

NA20 provides metering values for phase and residual currents, making them available for reading on a display or to communication interfaces.

Input signals are sampled 24 times per period and the RMS value of the fundamental component is measured using the DFT (Discrete Fourier Transform) algorithm and digital filtering.

With DFT the RMS value of 2nd, 3rd, 4th and 5th harmonic of phase current are also measured.

On the base of the direct measurements, the fundamental RMS value of the positive and negative sequence currents, the minimum-peak-fixed-rolling demand, mean-minimum-maximum absolute phase currents are processed.

The measured signals can be displayed with reference to nominal values or directly expressed in amperes.

— **Event storage**

Several useful data are stored for diagnostic purpose; the events are stored into a non volatile memory.

They are graded from the newest to the older after the "Events reading" command (ThyVisor) is issued:

- Sequence of Event Recorder (SER).
The event recorder runs continuously capturing in circular mode the last three hundred events upon trigger of binary input/output.
- Sequence of Fault Recorder (SFR).
The fault recorder runs continuously capturing in circular mode the last twenty faults upon trigger of binary input/output and/or element pickup (start-trip).
- Trip counters.

— **Digital Fault Recorder (Oscillography)**

Upon trigger of tripping/starting of each function or external signals, the relay records in COMTRADE format:

- Oscillography with instantaneous values for transient analysis.
- RMS values for long time periods analysis.
- Logic states (binary inputs and output relays).

Note - A license for Digital Fault Recorder function is required, for purchase procedure please contact Thytronic.

The records are stored in nonvolatile memory

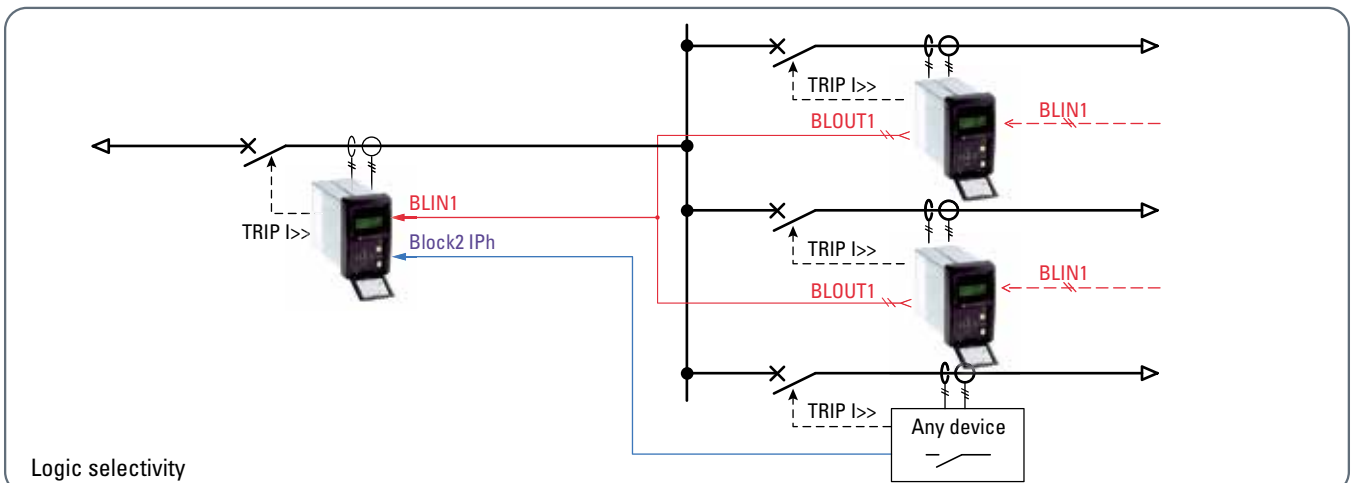

Logic selectivity

SPECIFICATIONS

GENERAL

— Mechanical data	
Mounting:	flush, projecting, rack or separated operator panel
Mass (flush mounting case)	2.0 kg
— Insulation tests	
Reference standards	EN 60255-5
High voltage test 50Hz	2 kV 60 s
Impulse voltage withstand (1.2/50 μ s)	5 kV
Insulation resistance	>100 M Ω
— Voltage dip and interruption	
Reference standards	EN 61000-4-29
— EMC tests for interference immunity	
1 MHz damped oscillatory wave	EN 60255-22-1 1 kV-2.5 kV
Electrostatic discharge	EN 60255-22-2 8 kV
Fast transient burst (5/50 ns)	EN 60255-22-4 4 kV
Conducted radio-frequency fields	EN 60255-22-6 10 V
Radiated radio-frequency fields	EN 60255-4-3 10 V/m
High energy pulse	EN 61000-4-5 2 kV
Magnetic field 50 Hz	EN 61000-4-8 1 kA/m
Damped oscillatory wave	EN 61000-4-12 2.5 kV
Ring wave	EN 61000-4-12 2 kV
Conducted common mode (0...150 kHz)	EN 61000-4-16 10 V
— Emission	
Reference standards	EN 61000-6-4 (ex EN 50081-2)
Conducted emission 0.15...30 MHz	Class A
Radiated emission 30...1000 MHz	Class A
— Climatic tests	
Reference standards	IEC 60068-x, ENEL R CLI 01, CEI 50
— Mechanical tests	
Reference standards	EN 60255-21-1, 21-2, 21-3
— Safety requirements	
Reference standards	EN 61010-1
Pollution degree	3
Reference voltage	250 V
Overvoltage	III
Pulse voltage	5 kV
Reference standards	EN 60529
Protection degree:	
• Front side	IP52
• Rear side, connection terminals	IP20
— Environmental conditions	
Ambient temperature	-25...+70 °C
Storage temperature	-40...+85 °C
Relative humidity	10...95 %
Atmospheric pressure	70...110 kPa
— Certifications	
Product standard for measuring relays	EN 50263
CE conformity	
• EMC Directive	89/336/EEC
• Low Voltage Directive	73/23/EEC
Type tests	IEC 60255-6

COMMUNICATION INTERFACES

Local PC USB	Type B
Network:	
• RS485	1200...57600 bps
• Ethernet 100BaseT	100 Mbps
Protocol	ModBus® RTU/IEC 60870-5-103/DNP3, TCP/IP

INPUT CIRCUITS

— Auxiliary power supply Uaux	
Nominal value (range)	24...48 Vac/dc, 115...230 Vac/110...220 Vdc
Operative range (each one of the above nominal values)	19...60 Vac/dc 85...265 Vac/75...300 Vdc
<i>Power consumption:</i>	
• Maximum (energized relays, Ethernet TX)	10 W (20 VA)
• Maximum (energized relays, Ethernet FX)	15 W (25 VA)
— Phase current inputs	
Nominal current I_n	1 A or 5 A selectable by DIP Switches
Permanent overload	25 A
Thermal overload (1s)	500 A
Rated consumption (for any phase)	≤ 0.002 VA ($I_n = 1$ A) ≤ 0.04 VA ($I_n = 5$ A)
— Residual current input	
Nominal current I_{En}	1 A or 5 A selectable by DIP Switch
Permanent overload	25 A
Thermal overload (1s)	500 A
Rated consumption	≤ 0.006 VA ($I_{En} = 1$ A), ≤ 0.012 VA ($I_{En} = 5$ A)
Binary inputs	
Quantity	2 or 5
Type	dry inputs
Max permissible voltage	19...265 Vac/19...300 Vdc
Max consumption, energized	3 mA
— Block input (Logic selectivity)	
Quantity	1
Type	polarized wet input (powered by internal isolated supply)
Max consumption, energized	5 mA

OUTPUT CIRCUITS

— Output relays K1...K6	
Quantity	6
• Type of contacts K1, K2	changeover (SPDT, type C)
• Type of contacts K3, K4, K5	make (SPST-NO, type A)
• Type of contacts K6	break (SPST-NC, type B)
Nominal current	8 A
Nominal voltage/max switching voltage	250 Vac/400 Vac
<i>Breaking capacity:</i>	
• Direct current (L/R = 40 ms)	50 W
• Alternating current ($\lambda = 0,4$)	1250 VA
Make	1000 W/VA
Short duration current (0,5 s)	30 A
— Block output (Logic selectivity)	
Quantity	1
Type	optocoupler
— LEDs	
Quantity	8
• ON/fail (green)	1
• Start (yellow)	1
• Trip (red)	1
• Allocatable (red)	5

GENERAL SETTINGS

— Rated values	
Relay nominal frequency (f_n)	50, 60 Hz
Relay phase nominal current (I_n)	1 A, 5 A
Phase CT nominal primary current (I_{np})	1 A...10 kA
Relay residual nominal current (I_{En})	1 A, 5 A
Residual CT nominal primary current (I_{Enp})	1 A...10 kA
— Binary input timers	
ON delay time (IN1 t_{0N} , IN2 t_{0N} ,...IN5 t_{0N})	0.00...100.0 s
OFF delay time (IN1 t_{0FF} , IN2 t_{0FF} ,...IN5 t_{0FF})	0.00...100.0 s
Logic	Active-ON/Active-OFF

— Relay output timers

Minimum pulse width t_{TR} 0.000...0.500 s

PROTECTIVE FUNCTIONS

— Base current - IB

Base current (I_B) 0.10...2.50 I_n

Note 1: assuming that the secondary rated current of the line CT's equals the rated current of the NA21 relay, the I_B value is the ratio between the rated current of the protected component and the CT's primary rated current.

— Thermal protection with RTD thermometric probes - 26

Alarm

- Alarm threshold θ_{ALx} ($x=1...8$) 0...200 °C
- Operating time $t_{\theta ALx}$ ($x=1...8$) 0...100 s

Trip

- Trip threshold $\theta_{>x}$ ($x=1...8$) 0...200 °C
- Operating time $t_{\theta >x}$ ($x=1...8$) 0...100 s

— *Note: The element becomes available when the MPT module is enabled and connected to Thybus*

— Undercurrent - 37

Common configuration:

- 37 Operating logic (Logic37) AND/OR

$I_{<}$ Element

Definite time

- 37 First threshold definite time ($I_{<def}$) 0.10...1.00 I_n
- $I_{<def}$ Operating time ($t_{<def}$) 0.04...200 s

— Negative sequence - 46

$I_{2>}$ Element

- $I_{2>}$ Curve type DEFINITE

IEC/BS A, B, C - ANSI/IEEE MI, VI, EI, I^{2t} or EM

- $I_{2CLP>}$ Activation time ($t_{2CLP>}$) 0.00...100.0 s
- $I_{2>}$ Reset time delay ($t_{2>RES}$) 0.00...100.0 s

Definite time

- 46 First threshold definite time ($I_{2>def}$) 0.100...10.00 I_n
- $I_{2>def}$ within CLP ($I_{2CLP>def}$) 0.100...10.00 I_n
- $I_{2>def}$ Operating time ($t_{2>def}$) 0.03...200 s

Inverse time

- 46 First threshold inverse time ($I_{2>inv}$) 0.100...10.00 I_n
- $I_{2>inv}$ within CLP ($I_{2CLP>inv}$) 0.100...10.00 I_n
- $I_{2>inv}$ Operating time ($t_{2>inv}$) 0.02...60.0 s

$I_{2>>}$ Element

- $I_{2CLP>>}$ Activation time ($t_{2CLP>>}$) 0.00...100.0 s
- $I_{2>>}$ Reset time delay ($t_{2>>RES}$) 0.00...100.0 s

Definite time

- 46 Second threshold definite time ($I_{2>>def}$) 0.100...40.00 I_n
- $I_{2>>def}$ within CLP ($I_{2CLP>>def}$) 0.100...40.00 I_n
- $I_{2>>def}$ Operating time ($t_{2>>def}$) 0.03...10.00 s

— Thermal image - 49

Common configuration:

- Initial thermal image $\Delta\theta_{IN}$ (Dth_{IN}) 0.0...1.0 $\Delta\theta_B$
- Reduction factor at inrush (K_{INR}) 1.0...3.0
- Thermal time constant τ (T) 1...200 min
- Dth_{IN} Activation time (t_{dthCLP}) 0.00...100.0 s

Dth_{AL1} Element

- 49 First alarm threshold $\Delta\theta_{AL1}$ (Dth_{AL1}) 0.3...1.0 $\Delta\theta_B$

Dth_{AL2} Element

- 49 Second alarm threshold $\Delta\theta_{AL2}$ (Dth_{AL2}) 0.5...1.2 $\Delta\theta_B$

$Dth>$ Element

- 49 Trip threshold $\Delta\theta$ ($Dth>$) 1.100...1.300 $\Delta\theta_B$

— Phase overcurrent - 50/51

$I_{>}$ Element

- $I_{>}$ Curve type ($I_{>Curve}$) DEFINITE
- IEC/BS A, B, C, ANSI/IEEE MI, VI, EI, RECTIFIER, I^{2t} or EM
- $I_{CLP>}$ Activation time ($t_{CLP>}$) 0.00...100.0 s
- $I_{>}$ Reset time delay ($t_{>RES}$) 0.00...100.0 s

Definite time

- 50/51 First threshold definite time ($I_{>def}$) 0.100...40.0 I_n
- $I_{>def}$ within CLP ($I_{CLP>def}$) 0.100...40.0 I_n
- $I_{>def}$ Operating time ($t_{>def}$) 0.04...200 s

Inverse time

- 50/51 First threshold inverse time ($I_{>inv}$) 0.100...20.00 I_n
- $I_{>inv}$ within CLP ($I_{CLP>inv}$) 0.100...20.00 I_n
- $I_{>inv}$ Operating time ($t_{>inv}$) 0.02...60.0 s

$I_{>>}$ Element

- Type characteristic DEFINITE or I^{2t}
- $I_{CLP>>}$ Activation time ($t_{CLP>>}$) 0.00...100.0 s
- $I_{>>}$ Reset time delay ($t_{>>RES}$) 0.00...100.0 s

Definite time

- 50/51 Second threshold definite time ($I_{>>def}$) 0.100...40.0 I_n
- $I_{>>def}$ within CLP ($I_{CLP>>def}$) 0.100...40.0 I_n
- $I_{>>def}$ Operating time ($t_{>>def}$) 0.03...10.00 s

Inverse time

- 50/51 Second threshold inverse time ($I_{>>inv}$) 0.100...20.00 I_n
- $I_{>>inv}$ within CLP ($I_{CLP>>inv}$) 0.100...20.00 I_n
- $I_{>>inv}$ Operating time ($t_{>>inv}$) 0.02...10.00 s

$I_{>>>}$ Element

- $I_{CLP>>>}$ Activation time ($t_{CLP>>>}$) 0.00...100.0 s
- $I_{>>>}$ Reset time delay ($t_{>>>RES}$) 0.00...100.0 s

Definite time

- 50/51 Third threshold definite time ($I_{>>>def}$) 0.100...40.0 I_n
- $I_{>>>def}$ within CLP ($I_{CLP>>>def}$) 0.100...40.0 I_n
- $I_{>>>def}$ Operating time ($t_{>>>def}$) 0.03...10.00 s

— Residual overcurrent - 50N/51N

$I_{E>}$ Element

- $I_{E>}$ Curve type DEFINITE

IEC/BS A, B, C - ANSI/IEEE MI, VI, EI, EM

- $I_{ECLP>}$ Activation time ($t_{ECLP>}$) 0.00...100.0 s
- $I_{E>}$ Reset time delay ($t_{E>RES}$) 0.00...100.0 s

Definite time

- 50N/51N First threshold definite time ($I_{E>def}$) 0.002...10.00 I_{En}
- $I_{E>def}$ within CLP ($I_{ECLP>def}$) 0.002...10.00 I_{En}
- $I_{E>def}$ Operating time ($t_{E>def}$) 0.04...200 s

Inverse time

- 50N/51N First threshold inverse time ($I_{E>inv}$) 0.002...2.00 I_{En}
- $I_{E>inv}$ within CLP ($I_{ECLP>inv}$) 0.002...2.00 I_{En}
- $I_{E>inv}$ Operating time ($t_{E>inv}$) 0.02...60.0 s

$I_{E>>}$ Element

- $I_{ECLP>>}$ Activation time ($t_{ECLP>>}$) 0.00...100.0 s
- $I_{E>>}$ Reset time delay ($t_{E>>RES}$) 0.00...100.0 s

Definite time

- 50N/51N Second threshold definite time ($I_{E>>def}$) 0.002...10.00 I_{En}
- $I_{E>>def}$ within CLP ($I_{ECLP>>def}$) 0.02...10.00 I_{En}
- $I_{E>>def}$ Operating time ($t_{E>>def}$) 0.03...10.00 s

$I_{E>>>}$ Element

- $I_{ECLP>>>}$ Activation time ($t_{ECLP>>>}$) 0.00...100.0 s
- $I_{ECLP>>>}$ Reset time delay ($t_{E>>>RES}$) 0.00...100.0 s

Definite time

- 50N/51N Third threshold definite time ($I_{E>>>def}$) 0.002...10.00 I_{En}
- $I_{ECLP>>>def}$ within CLP ($I_{ECLP>>>def}$) 0.002...10.00 I_{En}
- $I_{ECLP>>>def}$ Operating time ($t_{E>>>def}$) 0.03...10.00 s

— Negative sequence current / positive sequence current ratio - I_2/I_1

$(I_2/I_1)>$ Element

- $(I_2/I_1)_{CLP>}$ Activation time ($t_{21CLP>}$) 0.00...100.0 s
- $(I_2/I_1)>$ Reset time delay ($t_{21>RES}$) 0.00...100.0 s

Definite time

- I_2/I_1 First threshold definite time ($(I_2/I_1)_{>def}$) 0.10...1.00
- $(I_2/I_1)_{>def}$ within CLP ($I_{CLP>def}$) 0.10...1.00
- $(I_2/I_1)>$ Operating time ($t_{21>def}$) 0...15000 s

— CT supervision - 74CT

- 74CT Threshold ($S<$) 0.10...0.95

- 74CT Overcurrent threshold (I^*) 0.10...1.00 I_n

- $S<$ Operating time ($t_{S<}$) 0.03...200 s

— Connection diagram example

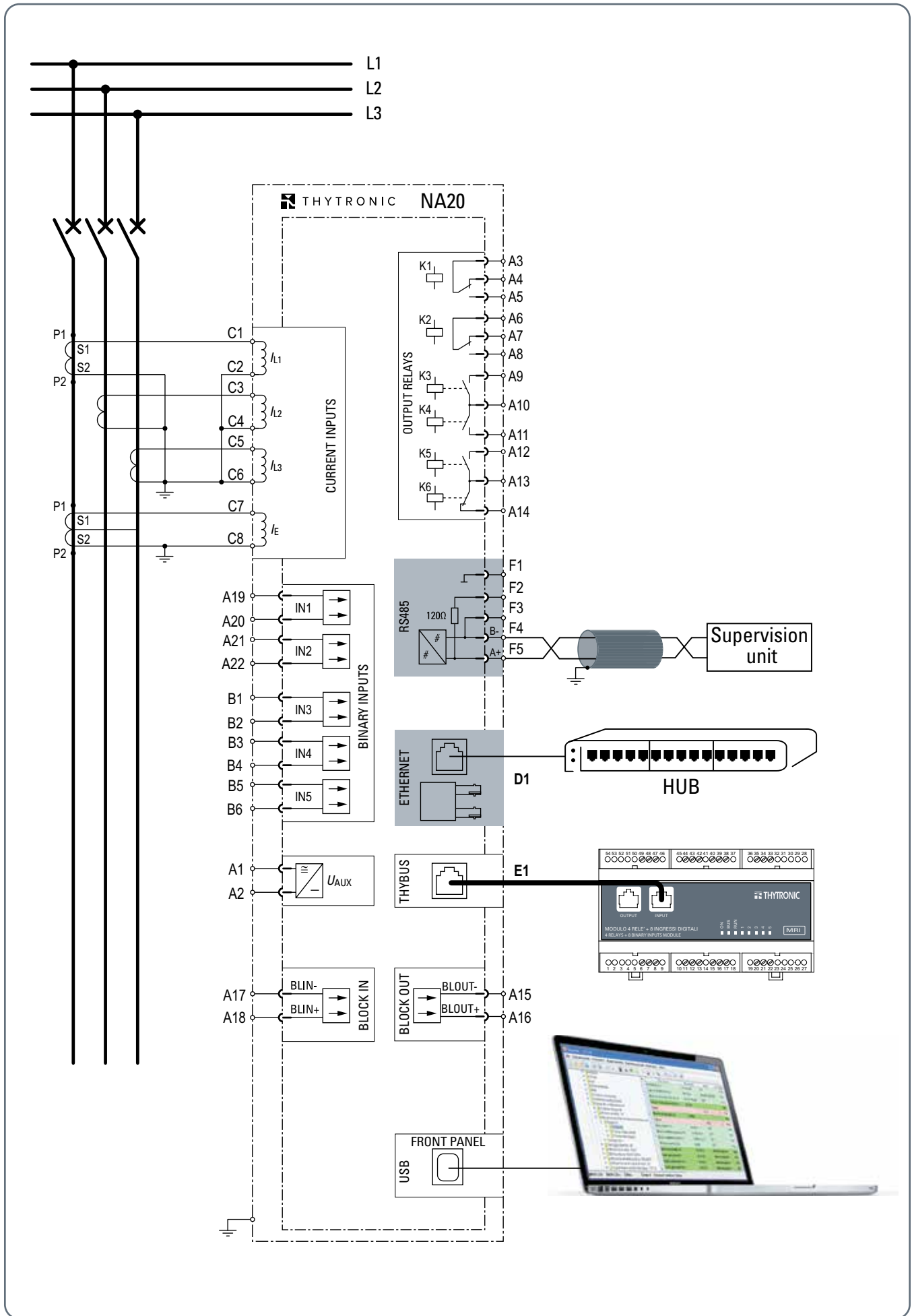

DIMENSIONS

FRONT VIEW

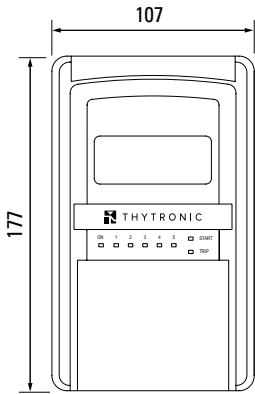

FLUSH MOUNTING

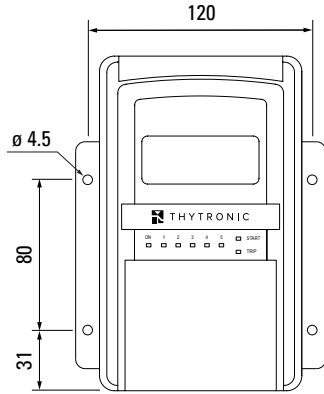

PROJECTING MOUNTING

REAR VIEW

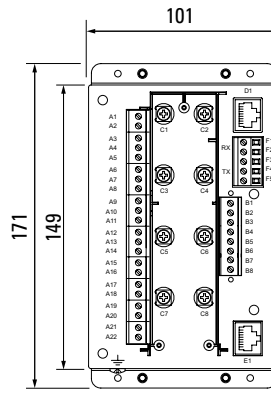

FLUSH MOUNTING

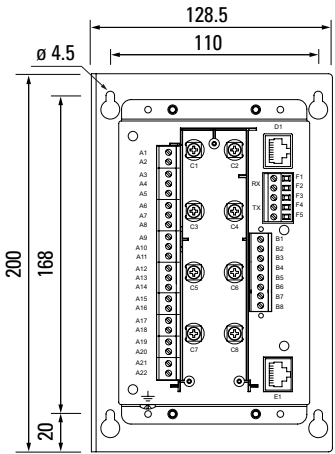

PROJECTING MOUNTING
(Separate operator panel)

SIDE VIEW

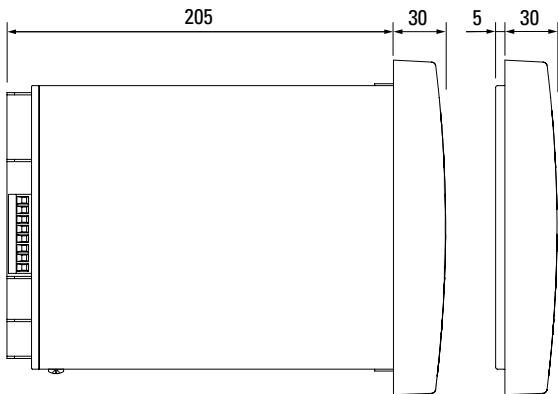

FLUSH MOUNTING

SEPARATE
OPERATOR PANEL

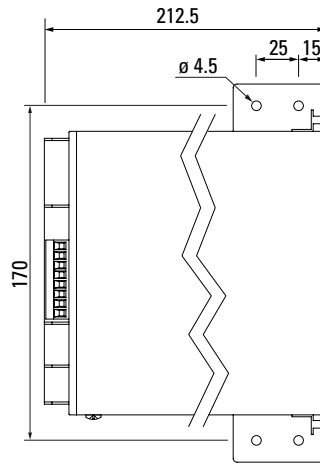

PROJECTING MOUNTING
(Separate operator panel)

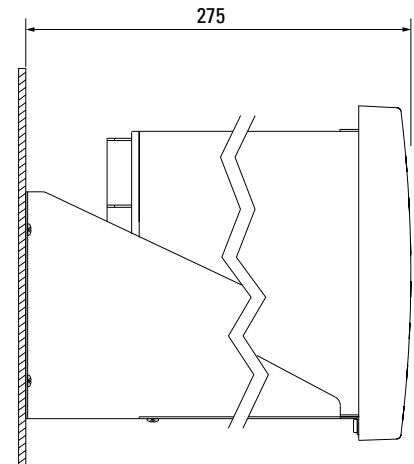

PROJECTING MOUNTING
(Stand alone)

RACK MOUNTING

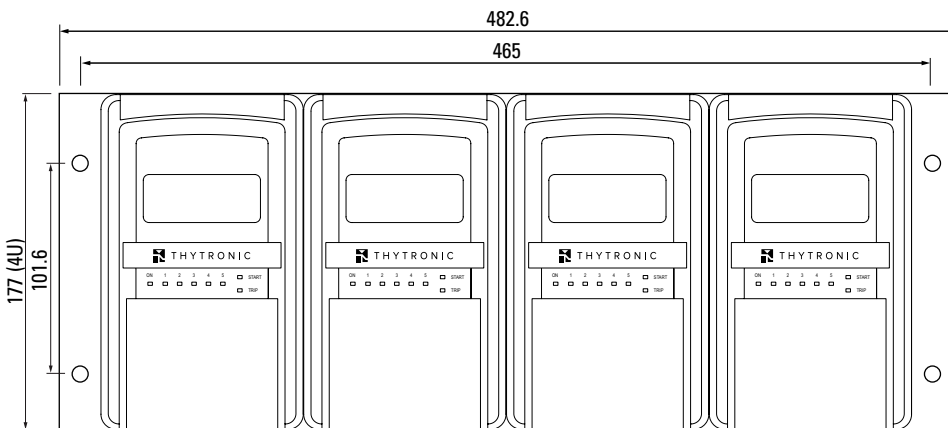

FLUSH MOUNTING CUTOUT

