



# DMRISO

I/O REMOTE MODULE

# MANUAL



CUI:RO17366414 - RC:J2005000752229

Silvestru Strapungere 13, Bl. E, Sc. B, Et. 2, 700003 Iasi, jud. Iasi, Romania

Telefon: +40.749.437109

Email: office@amperia.ro - Web: www.amperia.ro

## TABLE OF CONTENTS

<b>1</b>	<b>INTRODUCTION</b>	<b>3</b>
	Introduction.....	3
<b>2</b>	<b>DESCRIPTION</b>	<b>3</b>
	Main features.....	3
	Cyber Security.....	3
<b>3</b>	<b>TECHNICAL DATA</b>	<b>5</b>
<b>3.1</b>	<b>GENERAL</b>	<b>5</b>
	Mechanical data.....	5
	EMC tests for interference immunity.....	5
	Electromagnetic emission tests.....	5
	Climatic tests.....	6
	Mechanical tests.....	7
	Safety.....	7
	Reference specifications.....	7
	ENEL's General References.....	7
	Certifications.....	7
	Environmental conditions.....	7
<b>3.2</b>	<b>INPUTS CIRCUITS</b>	<b>8</b>
	Auxiliary power supply $U_{aux}$ .....	8
	Binary inputs.....	8
<b>3.3</b>	<b>OUTPUT CIRCUITS</b>	<b>8</b>
	Final relays.....	8
<b>3.5</b>	<b>COMMUNICATION CIRCUITS</b>	<b>8</b>
	ETH/FX.....	8
	RJ45/TX.....	8
<b>4</b>	<b>FUNCTION CHARACTERISTICS</b>	<b>9</b>
<b>4.1</b>	<b>I/O DESCRIPTIONS</b>	<b>9</b>
	Binary Inputs.....	9
	Output relays.....	10
	<b>APPENDIX</b>	<b>11</b>
	ENEL TYPICAL CONNECTIONS.....	11
	I/O CIRCUITS.....	13
	DIMENSIONS.....	14
	WIRING EXAMPLE DIAGRAM.....	15

# 1 INTRODUCTION

## — Introduction

DMRI I/O remote module is intended to provide digital inputs and output relays suitable both for standalone installation and both for DMC3 Panel according to Enel specifications DMI 9 00016. Polling of variables can be made using protocol IEC 61850.

# 2 DESCRIPTION

## — Main features

- “POWER” LED to signal proper power supply to CPU
- “ON” LED to signal proper operation of the DMRI device
- “LINK” LED to signal proper link between DMRI device and other network or DMC3 Panel device.
- ETH FX optic fiber communication interface
- ETH TX RJ45 communication interface
- MMP terminals for powering device
- 14 digital inputs with common negative
- 4 output relays
- Real time clock.

## — Cyber Security

Cybersecurity features implemented in DMC-3 Relays help to mitigate cyber threats, realising:

- Secured communication between DMC-3+DMRI protection relays and associated tool by **SSH** (Secure **SH**ell) protocols
- Password based user authentication
- **Role Based Access Control (RBAC)** authorization management
- Secured log storage (**Syslog** Service)

It is possible to identify the following operating areas:

- Configuration Management
- HW Systems and Networking Equipment
- Initial System Configuration
- Threat and Vulnerability Management
- Access Control
- Authentication and Authorization Management
- Auditing
- Network Communication Security

Described procedures have been selected considering the following standards and guide lines:

- ISO/IEC 27001:2013
- **NERC CIP** – **N**orth **A**merican **E**lectric **R**eliability **C**orporation **C**ritical **I**nfrastructure **P**rotection
- IEC 62351

IEC 62351 standard will be applied when specifically requested, covering the control of communication protocols and data flow.

### *Configuration Management*

Configuration Management is a set of procedures whose purpose is to check hardware, firmware, software and documentation changes in order to ensure that all devices are protected against unwanted changes before, during and after the implementation of the system.

### *2.HW Systems and Networking Equipment Configuration*

The devices are industrial and comply with the rules in terms of quality and electromagnetic disturbances immunity. Regarding heat dissipation only passive systems without fans are used. It is possible assign to devices IP addresses according to relevant network planning rules. On request it is possible to implement adequate HW protection mechanisms (e.g. anti-tamper etc.).

### *Initial System Configuration*

On protection relay are installed only and exclusively the network services necessary for protection application program execution, thus limiting the number of open TCP/UDP ports. All these services and O.S. are updated to the latest version indicated at release time. Accesses for “well-known” users are also removed and only a local non-administrator user is left active for the initial installation configuration of the device.

### *Threat and Vulnerability Management*

Device Operating System is supported by the relevant supplier ensuring compliance with security bulletins issued regularly and related patches.

### *Authentication and Authorization Management (AAM)*

AAM is based on “RBAC” (Rule Based Access Control) model, i.e. the device will allow or not the execution of certain functions according to assigned user role.

The following types of roles are available:

- “Administrator”: Equipment full control
- “Operator1”: First level limited Read/Write actions
- “Operator2”: Second level limited Read/Write actions

Auditing

The device keeps track, by "syslog" service, of the most important system operations/actions, such as accesses, configuration changes and the like.

Network Communication Security

The device does not use unencrypted protocols such as telnet, ftp. All communications necessary for equipment configuration eg: calibration, CID sending, etc. are routed via the "SSH" protocol, in encrypted mode.

Data exchange protocols with the SCADA, e.g. IEC61850 / DNP3 / MODBUSTCP are unencrypted, if IEC62351 specification is not expressly requested.

The synchronization protocols NTP, PTP are normally unencrypted.

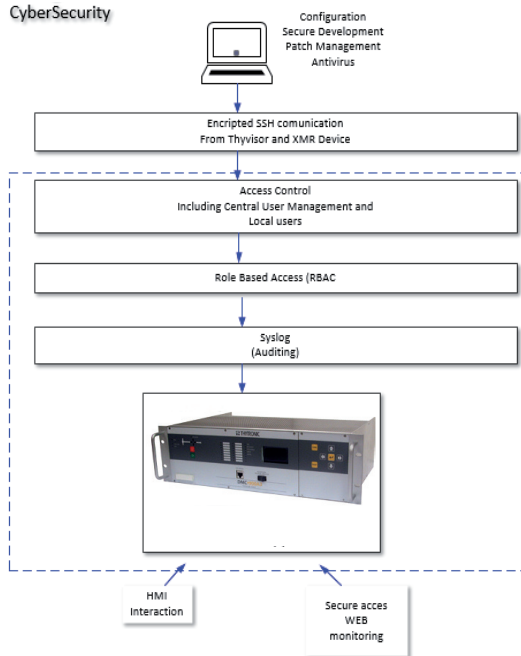

DMC-3 +DMRI Cybersecurity basic scheme

DMC-3+DMRI protection relay configuration capabilities and monitoring functionalities set problems related to the security and privacy of the data traffic exchanged between equipment and remote control centre.

The aspects to consider in this regard are:

- Traffic encryption, so it cannot be intercepted, analysed and eventually modified freely by third parties
- Authentication mechanism implementation in order to prevent any third parties false messages generation avoiding that they can be recognized as valid

User access procedure

Authentication mechanism expects to send authentication requests coming inbound card to a remote RADIUS authentication server that takes care user validation and it sends to CPU unit a positive or negative feedback based on the fact that the credentials provided by the user are correct or not and relevant associated user privilege level information

The RADIUS authentication as a reference to a remote server and uses a shared secret between card and server for validation of access requests. The configurator provides the possibility to define all parameters necessary for this authentication mode.

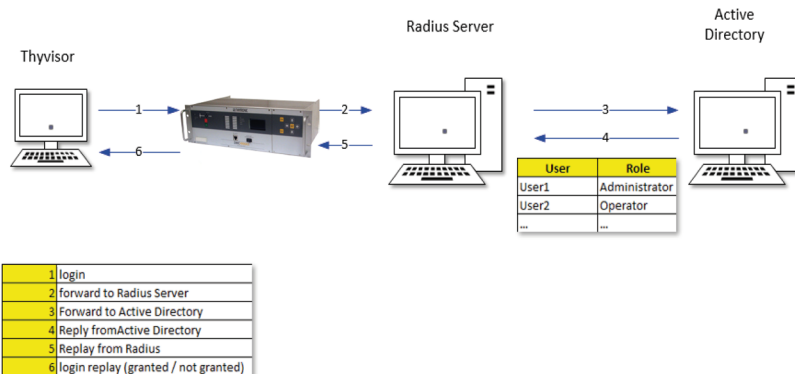

### 3 TECHNICAL DATA

#### 3.1 GENERAL

##### — Mechanical data

Mounting	Din Guide
Dimensions (high x width x depth)	160 x 75 x 115
Terminals	screw connections
Massima sezione dei conduttori	1.5 mm <sup>2</sup>
Mass	0.9 kg

##### — EMC tests for interference immunity

Reference standards	EN 61000-6-2
<i>Parts 6-2: Generic standards immunity for industrial environments</i>	
Reference standards	EN 61000-6-4
<i>Parte 6-4: Generic standards immunity for industrial environments</i>	
Reference standards	EN 61000-4-2, EN 61000-4-2/A1, EN 61000-4-2/A2
<i>Electrostatic discharge test</i>	
Reference standards	EN 61000-4-3
<i>Radiated, radio-frequency, electromagnetic field immunity test</i>	
Reference standards	EN 61000-4-4
<i>Electrical Fast Transient / Burst Immunity Test</i>	
Reference standards	EN 61000-4-5
<i>Testing and measurement techniques - Surge immunity test</i>	
Reference standards	EN 61000-4-6, EN 61000-4-6/A1
<i>Immunity to Conducted Disturbances, Induced by Radio Frequency Fields</i>	
Reference standards	EN 61000-4-8, EN 61000-4-8/A1
<i>Power Frequency Magnetic Field Immunity Test</i>	
Reference standards	EN 61000-4-10, EN 61000-4-10/A1
<i>Damped Oscillatory Magnetic Field Immunity Test</i>	
Reference standards	EN 61000-4-11
<i>Voltage Dips, Short Interruptions and Voltage Variations Immunity Tests</i>	
Reference standards	EN 61000-4-12
<i>Ring wave immunity test</i>	
Reference standards	EN 61000-4-16, EN 61000-4-16/A1
<i>est for immunity to conducted, common mode disturbances in the frequency range 0 Hz to 150 kHz</i>	
Reference standards	EN 61000-4-29
<i>Voltage dips, short interruptions and voltage variations on d.c. input power port immunity tests</i>	
Reference standards	EN 55011, 55011/A1, 55011/A2
<i>Industrial, scientific and medical equipment - Radio-frequency disturbance characteristics - Limits and methods of measurement</i>	
Reference standards	EN 50160
<i>Voltage characteristics of electricity supplied by public distribution systems</i>	

##### — Electromagnetic emission tests

###### *Interface enclosure*

Reference standards	IEC 61000-4-2 EN 60255-22-2
<i>Electrostatic discharge (Level 4)</i>	
• Contact discharge	8 kV
• Air discharge	15 kV
Reference standards	IEC 61000-4-3 EN 61000-4-3
<i>Radiated radio-frequency fields (Level 3)</i>	
• 80...3000 MHz AM 80%	10 V/m
• 900...1980 MHz Pulse modulated	10 V/m
Reference standards	IEC 61000-4-8 EN 61000-4-8
<i>Magnetic field 50 Hz (Level 5)</i>	
• 50 Hz continuous	100 A/m
• 50 Hz 1 s	1 kA/m
Reference standards	IEC 61000-4-10 EN 61000-4-10
<i>Damped oscillatory magnetic field (Level 5)</i>	
• Damped oscillatory wave 0.1 MHz	100 A/m
• Damped oscillatory wave 1 MHz	100 A/m

###### *Interface protective earth*

Reference standards	IEC61000-4-4 EN 60255-22-4
<i>Fast transient burst5/50 ns (Level 4)</i>	
• Fast transient	4 kV
Reference standards	IEC 61000-4-6 EN 61000-4-6
<i>Conducted radio-frequency fields (Level 3)</i>	
• 0.15...80 MHz AM 80% 1kHz	10 V

*Interface signal*

Reference standards	IEC61000-4-4 EN 61000-4-4
<i>Fast transient burst 5/50 ns (Level 4)</i>	
Fast transient	2 kV
Reference standards	IEC 61000-4-6
<i>Conducted radio-frequency fields (Level 3)</i>	
• 0.15...80 MHz AM 80% 1kHz	10 V
Reference standards	EC 61000-4-18 EN 60255-22-1
<i>Damped oscillatory wave (Level 3)</i>	
• 0.1 MHz and 1 MHz common mode	2.5 kV
• 0.1 MHz and 1 MHz differential mode	1.0 kV
Reference standards	EC 61000-4-12 EN 60255-22-1
<i>Damped oscillatory wave (Level 3)</i>	
• Ring wave common mode	2.0 kV
• Ring wave differential mode	1.0 kV
Reference standards	IEC 61000-4-16
<i>Power frequency (Level 3-4)</i>	
• 16 <sup>2/3</sup> continuous	100 V
• 16 <sup>2/3</sup> 1s	300 V
• 50 Hz continuous	100 V
• 50 Hz 1 s	300 V
• 0.015...150 kHz	10-1-1-10 V

*I/O and power supply interface*

Reference standards	IEC61000-4-4 EN 60255-22-4
<i>Fast transient burst 5/50 ns (Level 4)</i>	
Fast transient	2 kV, 4kV
Reference standards	IEC 61000-4-5
<i>High energy pulse (Level 4)</i>	
• $U_{aux}$ (line-to-ground)	4 kV
• $U_{aux}$ (line-line)	2 kV
Reference standards	IEC 61000-4-6 EN 61000-4-6
<i>Conducted radio-frequency fields (Level 3)</i>	
• 0.15...80 MHz AM 80% 1kHz	10 V
Reference standards	EC 61000-4-12 EN 60255-22-1
<i>Damped oscillatory wave (Level 3)</i>	
• 0.1 MHz common mode	2.0 kV
• 0.1 MHz differential mode	1.0 kV
Reference standards	IEC 61000-4-16
<i>Power frequency (Level 3-4)</i>	
• 16 <sup>2/3</sup> continuous	100 V
• 16 <sup>2/3</sup> 1s	300 V
• 50 Hz continuous	100 V
• 50 Hz 1 s	300 V
• 0.015...150 kHz	10-1-1-10 V
Reference standards	IEC 61000-4-17
<i>Ripple on d.c. input power port immunity test</i>	
• Variation	10%
Reference standards	IEC 61000-4-29
<i>Voltage dips, short interruptions and voltage variations on dc input power port immunity tests</i>	
• Lasting voltage dips with UT=40%	100 ms
• Lasting short interruptions with UT=0%	50 ms
• Lasting voltage variation Un=80...120%	10 s

**— Climatic tests**

Reference standards	IEN 60068-2-1
<i>Environmental testing: Part 2-1: Tests – Test A: Cold</i>	
Reference standards	IEN 60068-2-2
<i>Environmental testing: Part 2-2: Tests - Test B: Dry heat</i>	
Reference standards	IEN 60068-2-14
<i>Environmental testing: Part 2: Tests - Test N: Change of temperature</i>	
Reference standards	IEN 60068-2-78
<i>Environmental testing: Prova Cab: Damp heat, steady state</i>	
Reference standards	IEN 60068-3-1
<i>Environmental testing: Part 3-1: Supporting documentation and guidance - Cold and dry heat tests</i>	
Reference standards	IEN 60068-3-4
<i>Environmental testing: Part 3-4: Supporting documentation and guidance - Damp heat tests</i>	

**— Mechanical tests**

Reference standards	EN 60255-21-1 EN 60255-21-2 RMEC01
<i>Vibration, shock, bump and seismic tests on measuring relays and protection equipment</i>	
• EN 60255-21-1 Vibration tests (sinusoidal)	Class 1
• EN 60255-21-2 Shock and bump test	Class 1

**— Safety**

Reference standards	EN 60255-5
Part 5: Insulation coordination for measuring relays and protection equipment - Requirements and tests	
50Hz test (1 min):	
• Power circuit	2 kV
• Input circuits	2 kV
• Output circuits	2 kV
• Output circuits (between open contacts)	1 kV
• Communication port	1 kV
Insulation resistance	>100 MΩ
Reference standards	EN 60255-5
<i>Insulation coordination for measuring relays and protection equipment (1.2/50 ns):</i>	
• Power circuit	5 kV
• Input circuits	5 kV
• Output circuits	5 kV
• Output circuits (between open contacts)	5 kV
Reference standards	EN 61010-1
<i>Safety requirements for electrical equipment for measurement, control and laboratory use</i>	
Pollution degree	3
Reference voltage	250 V
Overvoltage category	IV
Reference standards	EN 60204-1
<i>Safety of machinery - Electrical equipment of machines - Part 1: General requirements</i>	

**— Reference specifications**

Protection and control device for HV/MV substation – Multifunctional feeder protection (MFP)	ENEL GSTP101
Protection and control device for HV/MV substation – Remote Input/Output module (RIO) for the MFP	ENEL GSTP102
Protection and control device for HV/MV substation – Communication profile (according to IEC 61850) for the MFP remote input/output module (MFP-RIO)	GSTP104-01
Electrical Diagrams for Protection and control device for HV / MV substation – Remote Input / Output Module RIO for the MFP	GSTX102-01

**— ENEL's General References**

Reference standards	IEC61850-x
Reference standards	IEE 802.x
<i>Standard for the Ethernet port</i>	
ENEL's Table (Tabella di unificazione ENEL)	DV25
<i>Spring Terminals (Morsetti a molla)</i>	
ENEL's Table (Tabella di unificazione ENEL)	DV29
Terminals	
ENEL's Table (Tabella di unificazione ENEL)	DV1000 rev .01
<i>Data Transmission Characteristics (Comunicazione dati, caratteristiche elettriche e funzionali)</i>	
ENEL's Table (Tabella di unificazione ENEL)	DV801A
<i>Connectors [Connettori (34 poli)]</i>	

**— Certifications**

<i>CE Conformity</i>	
• EMC Directive	2014/30/CE
• Low Voltage Directive	2014/35/CE

**— Environmental conditions**

Ambient temperature	-25...+70 °C
Storage temperature	-40...+85 °C
Relative humidity	≤95 %
Atmospheric pressure	860...1060 kPa

### 3.2 INPUTS CIRCUITS

#### — Auxiliary power supply $U_{aux}$

<i>Voltage</i>	
• Nominal value (range)	110 V-
• Operative range	77...143 V- ( $\pm 30\%$ )
• Power consumption	4.4 W
• Cooling	Natural

#### — Binary inputs

Inputs number:	14
Type	optocoupler
Operative range	as $U_{aux}$
Min activation voltage	82.5 V
Reset voltage	66 V
Max consumption, energized	3 mA
<i>Timer connected to logical inputs</i>	
• Acquisition delay OFF/ON (INx-x $t_{ON}$ )	0.00...100.0 s
• Acquisition delay ON/OFF (INx-x $t_{OFF}$ )	0.00...100.0 s
Logic	Active-ON/Active-OFF

### 3.3 OUTPUT CIRCUITS

#### — Final relays

Number	4
<i>Type of contacts</i>	
• 52CH, 52AP, Trip MV	closing (SPST-NO, type A)
• 80S NC	closing (SPST-NC, type B)
• 80S NO	closing (SPST-NC, type A)
Nominal current	8 A
Nominal voltage	110 V-
DC power interruption power (L/R = 40 ms)	0,5 A

### 3.5 COMMUNICATION CIRCUITS

#### — ETH/FX

<i>Ethernet</i>	100 Base FX
• Connection	LC - Optic cable 1300 nm
• Protocol	ModBus®TCP/IP, IEC61850

#### — RJ45/TX

<i>Ethernet</i>	100 Base T
• Connection	RJ45
• Protocol	ModBus®TCP/IP, IEC61850

Settings of IP Address can be made from **Commands \Set Params \Set not resettable parameters** menu and after executing command right clicking on it.

It is possible reset IP address by IP RESET push-button present on device front.

Default IP ADDRESS

**192.168.2.4 MASK 255.255.255.0**

## 4 FUNCTION CHARACTERISTICS

### 4.1 I/O DESCRIPTIONS

#### — Binary Inputs

Are available 14 inputs. The dry inputs must be powered with an external voltage, (usually the auxiliary power supply).

The connections are shown in the schematic diagrams.

The following settings can be used to configure each input:

- Logic Active-ON (activated when powered), or Active-OFF (activated when power is turned off)
- ON Timer (OFF-to-ON time delay) and OFF Timer (ON-to-OFF time delay).
- Binary input allocation.

Adjustable debounce timer allows any transient to decay avoiding false activation of the input; the positive transition is acquired if the input is permanently high for a time interval longer than the  $t_{ON}$  setting delay; similarly for the negative transitions, the negative transition is acquired if the input is permanently high for a time interval longer than the  $t_{OFF}$  setting delay.

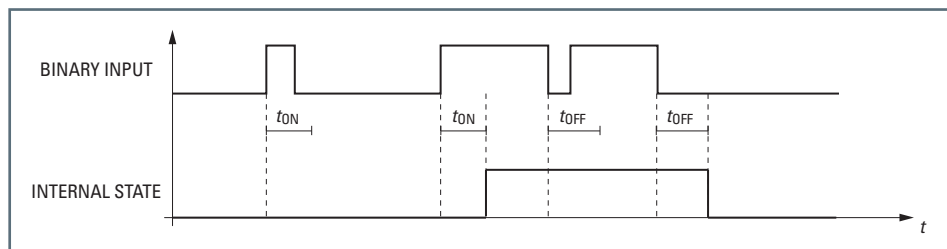

Each binary inputs of the external module DMRI (DMRI1-1...DMRI1-14 e DMRI2-1...DMRI2-14) can be matched to one of the following default function (only when DMRI module is used connected with DMC3 Panel according to Enel specifications DMI 9 00016).

**The following table represents ONLY an example, because Binary Inputs Functions can change being dependent on plant requirements.**

FUNCTION	Binary Inputs
	DMRI1-X
Position- SZTT closed (89ccX)	■
Position SZTT open (89ccX)	■
52 Inserted	■
52 Selected	■
63G Alarm	■
63G Trip	■
Lack of voltage MT CB (80S)	■
Trip spring charger CB (6L)	■
Block CH-port (BLP)	■
Springs Discharged (X33)	■
.....	

## — Output relays

Each output relay may be programmed with following operating mode:

- *Operation MODE (No latched, Pulse, Latched).*
- *Logic (Energized/De-energized).*

To each output relay a programmable timer is matched (*Minimum pulse width* parameter).

All parameters are available inside the **Set \ Rele** menu.

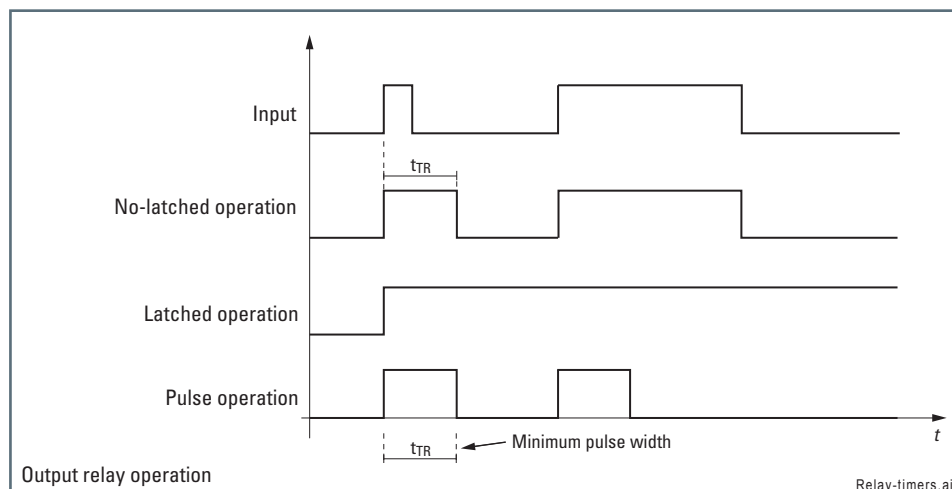

Any change to the settings can be affected at any time, also with the relay on duty, separately for each relay.

Notes:

- When de-energized operating mode is set, the relay remains in rest condition if no trip command is in progress.
- When energized operating mode is set, the relay remains in operating condition if no trip command is in progress and the auxiliary supply is powered on.
- When no-latched operating mode is set (*Operation MODE No latched*), the output relay resets at the end of the trip condition. To each output relay a programmable timer is matched (minimum pulse width operation).
- When latched operating mode is set (*Operation MODE Latched*), the output relay doesn't reset at the end of the trip condition; it stays ON until a reset command is issued (RESET key, ThySetter or communication command).
- When pulse operating mode is set (*Operation MODE Pulse*), the output relay resets after a  $t_{TR}$  programmable delay regardless of the trip condition.
- It is advisable to make sure that the output contact technical data are suitable for load (Nominal current, breaking capacity, make current, switching voltage,...).

Matching every output relay to any protective element is freely programmable inside the Setpoints submenus according a tripping matrix structure.

Each relays onboard on module DMRI (DMRI1-1...DMRI1-14 e DMRI2-1...DMRI2-14) can be associated to each of the protection function of DMC3 panel.

## APPENDIX

### — ENEL TYPICAL CONNECTIONS

The following tables represent **ONLY** an example, because related functions can change being dependent on plant requirements

DMRI N°1								
		Location	Function	MODBUS parameters				
						Address Hi (HEX)	Address Low (HEX)	Format
DIG IN	Module MODBUS TCP/IP 52MT	Bay 52 LMT-52 RIF 52 TFN 52 AT	Position SZTT closed (89ccX) [Posizione SZTT chiuso (89ccX)]	(1x)	10000	00		1 bit
			Position SZTT open (89caX) [Posizione SZTT aperto (89caX)]	(1x)	10001	01		1 bit
			52 inserted [52 inserito]	(1x)	10002	02		1 bit
			52 disconnected [52 sezionato]	(1x)	10003	03		1 bit
			63G Allarm. [63G All.]	(1x)	10004	04		1 bit
			63G Trip. [63G SC.]	(1x)	10005	05		1 bit
			Lack of voltage CB MV (80S) [Manca tensione Inter.re MT (80S)]	(1x)	10006	06		1 bit
			Trip Spring Charger CB (6L) [Scatto int.re carica molle (6L)]	(1x)	10007	07		1 bit
			Block Close-door for return voltage (BLP) [Blocco CH-porta per tensione di ritorno (BLP)]	(1x)	10008	08		1 bit
			Springs discharged (X33) [Molle scariche (X33)]	(1x)	10009	09		1 bit
				(1x)	10010	01	01	bit
				(1x)	10011	01	11	bit
				(1x)	10012	01	21	bit
	(1x)	10013	01	31	bit			
DIG OUT			Block Close-door for return voltage(BLP) [Blocco CH-porta per V.ritorno BLP]	(1x)	20000	00		1 bit
			80S (lack of Earthing Transformer /HV Customer Bay command) [80S (comando a mancanza TFN /Montante cliente AT)]	(1x)	20001	01		1 bit
				(1x)	20002	02		1 bit
				(1x)	20003	03		1 bit

DMRI N°2 (DMC922 Earthing Transformer)								
		Location	Function	MODBUS parameters				
						Address Hi (HEX)	Address Low (HEX)	Format
DIG IN	Module MODBUS TCP/IP 52MT	Bay 52 LMT-52 RIF 52 TFN 52 AT	26 Allarm Earthing Transformer/ Moving Coil [26 All. TFN/Bobina Mobile]	(1x)	10000	00		1 bit
			26 Trip Earthing Transformer/ Moving Coil [26 Sc. TFN/Bobina Mobile]	(1x)	10001	01		1 bit
			26 Allarm Resistor Serie/Parallelo [26 All. Resistenze Serie/Parallelo]	(1x)	10002	02		1 bit
			26 Trip Resistor Serie/Parallelo [26 Sc. Resistenze Serie/Parallelo]	(1x)	10003	03		1 bit
			97 Allarm Earthing Transformer/ Moving Coil [97 All. TFN/Bobina Mobile]	(1x)	10004	04		1 bit
			97 Allarm Earthing Transformer/ Moving Coil [97 Sc. TFN/Bobina Mobile]	(1x)	10005	05		1 bit
			99 Allarm Earthing Transformer/ Moving Coil [99 All. TFN/Bobina Mobile]	(1x)	10006	06		1 bit
			99 Allarm Earthing Transformer/ Moving Coil [99 Sc. TFN/Bobina Mobile]	(1x)	10007	07		1 bit
			Resistor Parallelo caX/ Moving Coil [Resistenza Parallelo caX / Bobina Mobile]	(1x)	10008	08		1 bit
			Resistor Parallelo ccX caX/ Moving Coil [Resistenza Parallelo ccX caX / Bobina Mobile]	(1x)	10009	09		1 bit
			42 RT engine moving coil [42 RT motore Bobina Mobile]	(1x)	10010	01	01	bit
			42 Eater Moving Coil [42 Scaldiglie Bobina Mobile]	(1x)	10011	01	11	bit
				(1x)	10012	01	21	bit
				(1x)	10013	01	31	bit
DIG OUT			Resistor Parallelo AX/ Moving Coil [Resistenza Parallelo AX / bobina Mobile]	(1x)	20000	00		1 bit
			Resistor Parallelo CX/ Moving Coil [Resistenza Parallelo CX / Bobina Mobile]	(1x)	20001	01		1 bit
				(1x)	20002	02		1 bit
				(1x)	20003	03		1 bit

I/O CIRCUITS

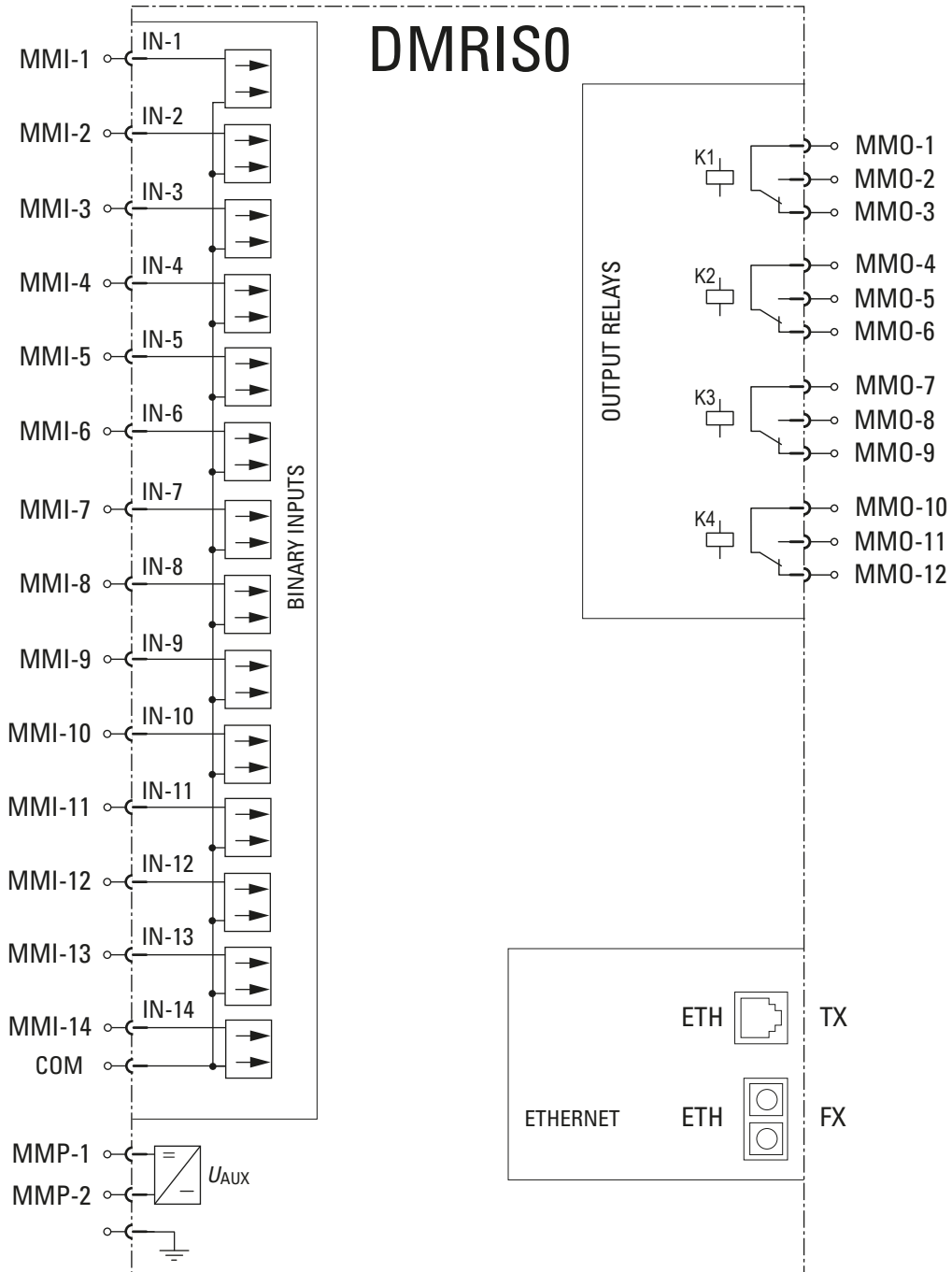

— DIMENSIONS

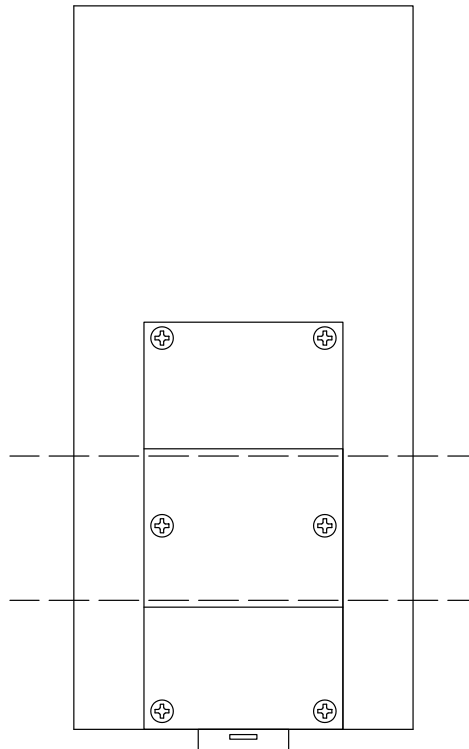
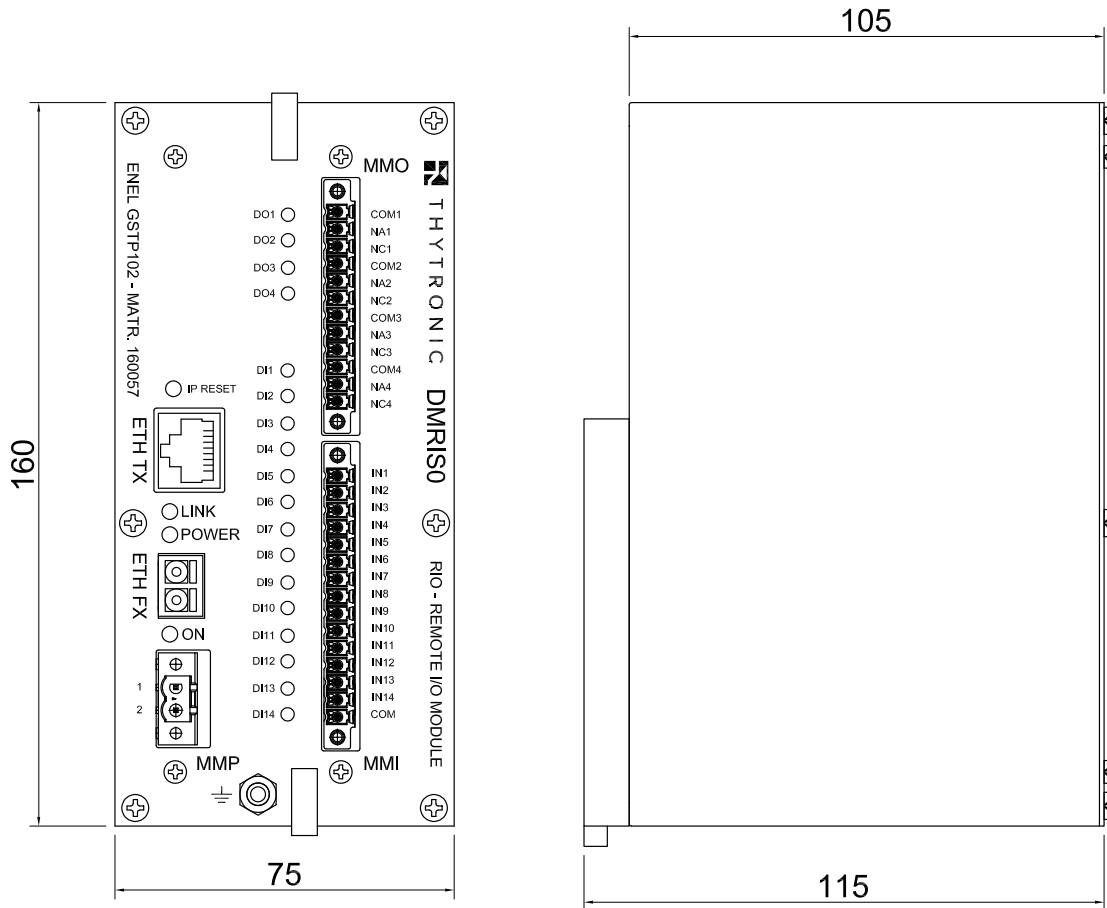

DIN RAIL FIXTURE

— WIRING EXAMPLE DIAGRAM

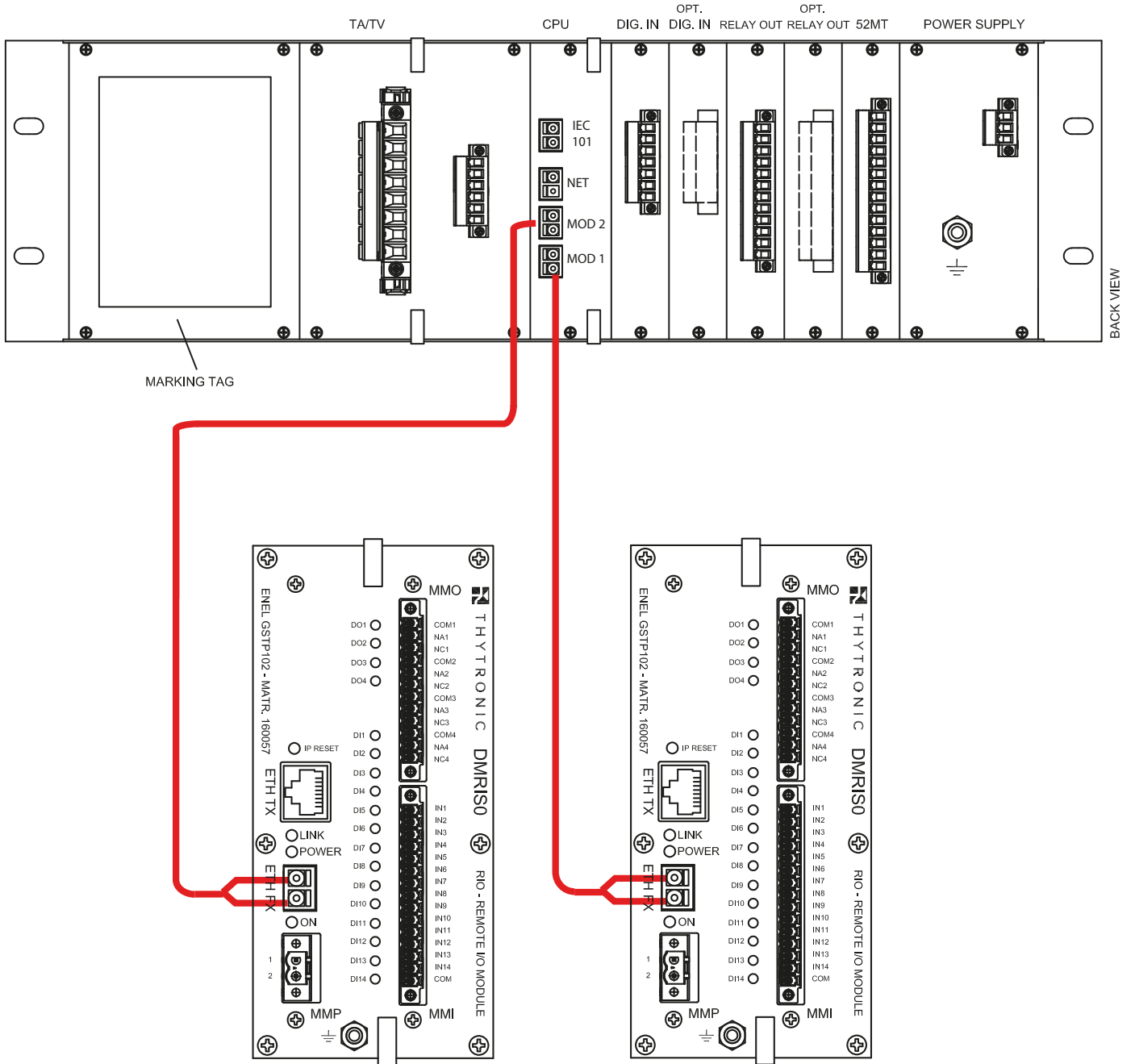



# THYTRONIC

ENERGY FOR A SAFER FUTURE



CUI:RO17366414 - RC:J2005000752229

Silvestru Strapungere 13, Bl. E, Sc. B, Et. 2, 700003 Iasi, jud. Iasi, Romania

Telefon: +40.749.437109

Email:office@amperia.ro - Web: www.amperia.ro

---

**Sediu:** 20139 Milano - Piazza Mistral, 7 - Tel. +39 02 574 957 01 ra - Fax +39 02 574 037 63

**Plantă:** 35127 Padova - Z.I. Sud - Via dell'Artigianato, 48 - Tel. +39 049 894 770 1 ra - Fax +39 049 870 139 0